



Product Specifications

Model: DSP-C1 (Plated Steel) & DSS-C1 (Stainless Steel) Flush Floor Sleeve for Fresh Concrete -

The Pelsue Model #DSP-C1 & #DSS-C1 Floor Sleeve is designed to be installed in a freshly-poured concrete floor surface. The sleeve provides a fixed receiver

for any PELSUE Brand offset arm or davit system. After installation, the installed sleeve is flush to the floor's surface thereby eliminating any protruding object or potential trip hazard. Caps can be purchased separately in order to seal off the receiver hole when not in use.

General Specifications:

Product is Designed & tested to be used in 2 General Applications:

1. As a mounting point for an offset davit system to be utilized as a personnel or equipment lowering, lifting, and positioning device.
Man Rated Load Capacity.....350 LBS. (159 KG.) Maximum at up to a 48" offset
2. As a mounting point for an offset davit system to be utilized as an anchorage for a personal fall arrest system.

Compliance.....Designed and tested as an Anchorage for the attachment of Personal Fall Arrest Equipment as per OSHA Regulations (Standards 29 CFR) Part 1926

****Warning! A 900 LB. maximum arrest force fall arrest device must be used when this product is employed as part of a complete fall arrest system.**

Materials & Construction:

General Construction.....Welded Carbon Steel (DSP-C1) or Welded Stainless Steel (DSS-C1)

****NOTE - The Mounting Requirements shown on this document are guidelines for safe-installation. Consult the Proof Load Table in this document & have concrete & installation of system approved by installing engineer.**

Anti-Friction Components:

- Grey PVC Slip Plate & ABS Plastic Friction Sleeve

Weight:

Weight.....22 LBS.

Mounting Requirements:

Concrete Strength: 2000 PSI
Concrete Thickness: 6 inches (152 mm)
Concrete Reinforcement: Single 1/2 inch (13mm) Diameter Steel Rebar on 12 inch (305 mm) Centers Lateral and Longitudinal



2500 S. Tejon St.
Englewood, CO 80110
Ph: 1-800-525-8460, (303) 936-7432
Fax: (303)934-5581
Web: www.pelsue.com E-mail: sales@pelsue.com



Product Specifications

**** ALL DIMENSIONS IN INCHES UNLESS ****
**** OTHERWISE STATED ****

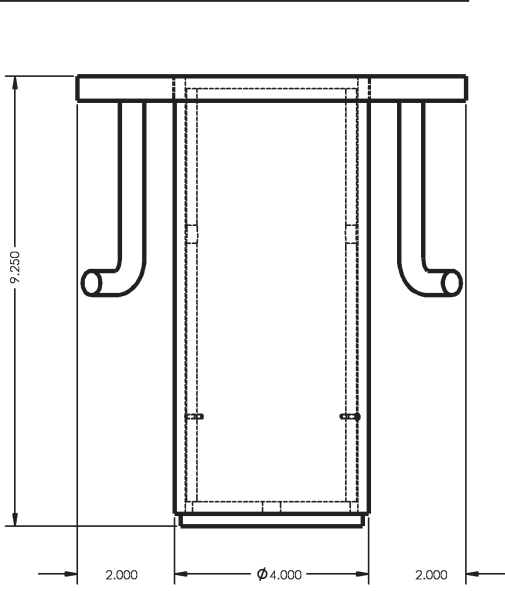

FRONT VIEW

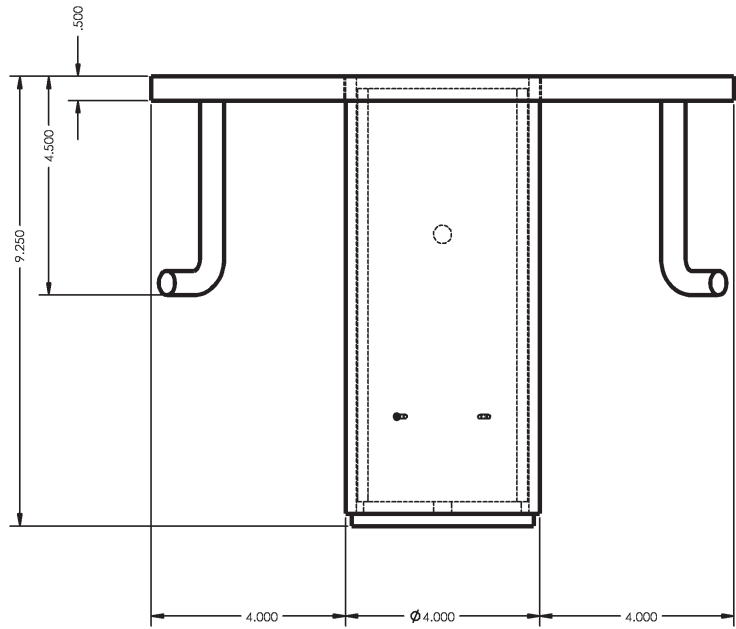

SIDE VIEW

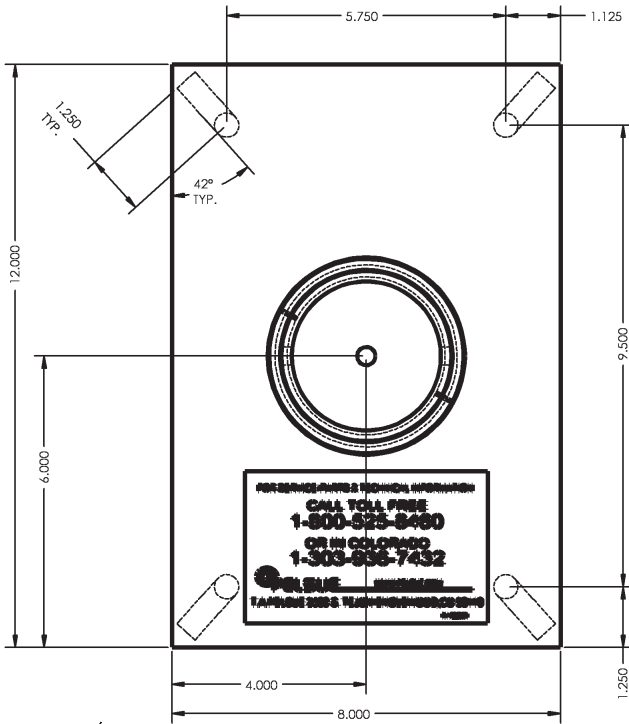

TOP VIEW

DS Series Permanent Sleeve Systems -- Proof Load Tabulation

Product	Accompanying System	Product Offsets	Proof Load* Attained at Maximum Offset	Torsional Proof Load About Sleeve Center	Fall Arrest Anchorage Compliance** at Maximum Offset	Personnel Hoist & Retrieval Ratings*** at Maximum Offset
DS Series Permanent Sleeve Systems	DK1824	18" & 24"	5000 LB.	10000 Ft.-Lb.	ANSI Z359 (1 person) ANSI A10.14 (1 person) OSHA 1926.502 (1 person)	1 Person (350 LBS. / 159 KG Maximum Weight) with better than a 14:1 Factor of Safety
	DK3036	30" & 36"	3600 LB.	10800 Ft.-Lb.	ANSI A10.14 (1 person) OSHA 1926.502 (1 person)	1 Person (350 LBS. / 159 KG Maximum Weight) with better than a 10:1 Factor of Safety
	DK4248	42" & 48"	1800 LB.	7200 Ft.Lb.	ANSI A10.14 (1 person) OSHA 1926.502 (1 person)	1 Person (350 LBS. / 159 KG Maximum Weight) with better than a 5:1 Factor of Safety

* Proof Load is defined as the load attained on the structure and sustained by the structure for a period of 2 minutes with no visible signs of structural failure.

** Compliance is dependent upon usage of product within manufacturer's guidelines and in conjunction with only approved PELSUE brand equipment and sub components

*** Ratings are arrived at by PELSUE engineering taking into account test data for each structure, applicable and relevant governing standards, and overall good sense. Ultimately, published ratings should be used as a reference allowing the end user to arrive at a comfortable Factor of Safety based upon usage conditions and experience.



2500 S. Tejon St.
 Englewood, CO 80110
 Ph: 1-800-525-8460, (303) 936-7432
 Fax: (303)934-5581
 Web: www.pelsue.com E-mail: sales@pelsue.com