

PORTABLE GRAVITY OPERATED EYEWASH

EL483

The portable gravity operated eyewash features a 35 litre capacity, FDA high-density green polyethylene tank which provides a full 15 minute full pattern flushing at 1.5 litres per minute.

The fold-down eyewash arm has a positive upper limit stop that also covers and protects the spray outlets when not in use. The tank has a handle on top to allow for easy handling. A wide-fill opening with threaded cap permits easy inspection, cleaning and filling. It is supplied with wall bracket to fix the eyewash securely on wall.

Meets the ANSI Z 358.1-2009 and AS4775-2007 Standards

OPTIONS (Additional Costs may apply)

Anti-bacteria Preservative Additive: ESS200

Anti-bacteria Preservative for use in portable eyewash stations.

One 237 ml bottle will preserve 22.5 - 75.5 litres of potable water for up to six months.

Four bottles per carton. Directions on the bottle.



Product Codes

EL483 Portable Gravity Fed Eyewash

Technical Information

Capacity	35L
Tank	FDA high-density green polyethylene
Flushing	1.5 lpm
Measurements H/D/W	395 x 600 x 250 mm

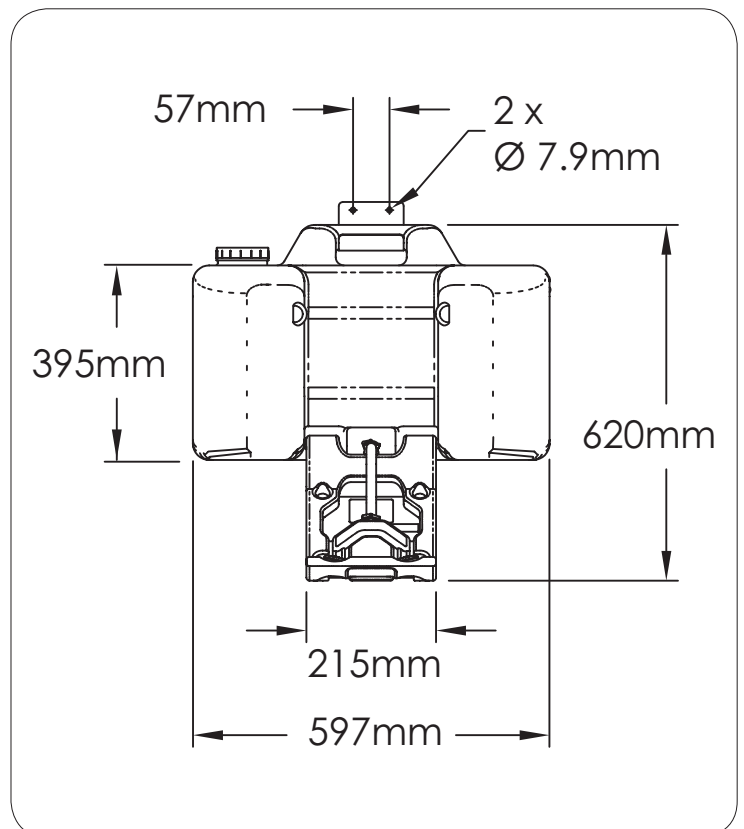

July 2016

Call 1300 369 273
www.enware.com

Enware Australia Pty Limited
9 Endeavour Rd Caringbah NSW 2229 Australia
Ph: +61 2 8556 4000 Fax: +61 2 8556 4055

installingconfidence

1. INSTALLATION INSTRUCTIONS

1.1 INSTALLATION INSTRUCTIONS

RECOMMENDED TOOLS: Two ¼" diameter anchors suitable for supporting filled eyewash (approximately 40kgs) and tools needed to install these anchors.

LOCATION OF UNIT: The Portable Eyewash should be installed in close proximity to potential accident areas. It should be clearly identified, free from obstructions and easily accessible.

1. Wall mount with 'J' bracket. Eyewash nozzles should be between 840mm and 1143mm above the floor when eyewash arm is in the active (lowered) position.

IMPORTANT: Filled eyewash unit is heavy (approximately 40kg). Wall bracket anchors or shelf must be strong enough to support the filled eyewash and the weight of a worker leaning on eyewash.

2. Place on level surface/bracket, fill up to fill line, and screw the threaded cap back on. If installed as indicated, eyewash unit will provide 15-minutes duration flow.

3. Take proper precautions to help prevent the growth of potentially harmful bacteria in eyewash tanks. (Refer to Maintenance Instructions).

1.2 MIXING INSTRUCTIONS FOR BACTERIOSTATIC PRESERVATIVE:

Follow instructions on the side of each bottle. Units with capacities of 6-20 gallons should be mixed with the full 8 ounces contained in each bottle. It is recommended that the tentative potable water be replaced every 180 days. This procedure may be followed with weekly 15-second testings. (Water consumed in testing should be replaced with clean potable water.)

1.3 OPERATING INSTRUCTIONS

Instruct all employees in the use of this Emergency Eyewash. Test weekly. Personnel should be assigned to check eyewash liquid level daily.

1. Lead patient to nearest eyewash station. Seconds can make the difference in preventing serious eye injury.
2. Pull orange eyewash arm firmly. Eyewash arm will drop to activate eyewash.
3. Lower head until eyes enter eyewash stream. Use thumbs and forefingers to hold eyelids open. Flush for 15 minutes.
4. Seek qualified medical attention immediately.

2. PRODUCTS COMPONENTS AND SPARE PARTS LIST

2.1 FRONT AND SIDE VIEW

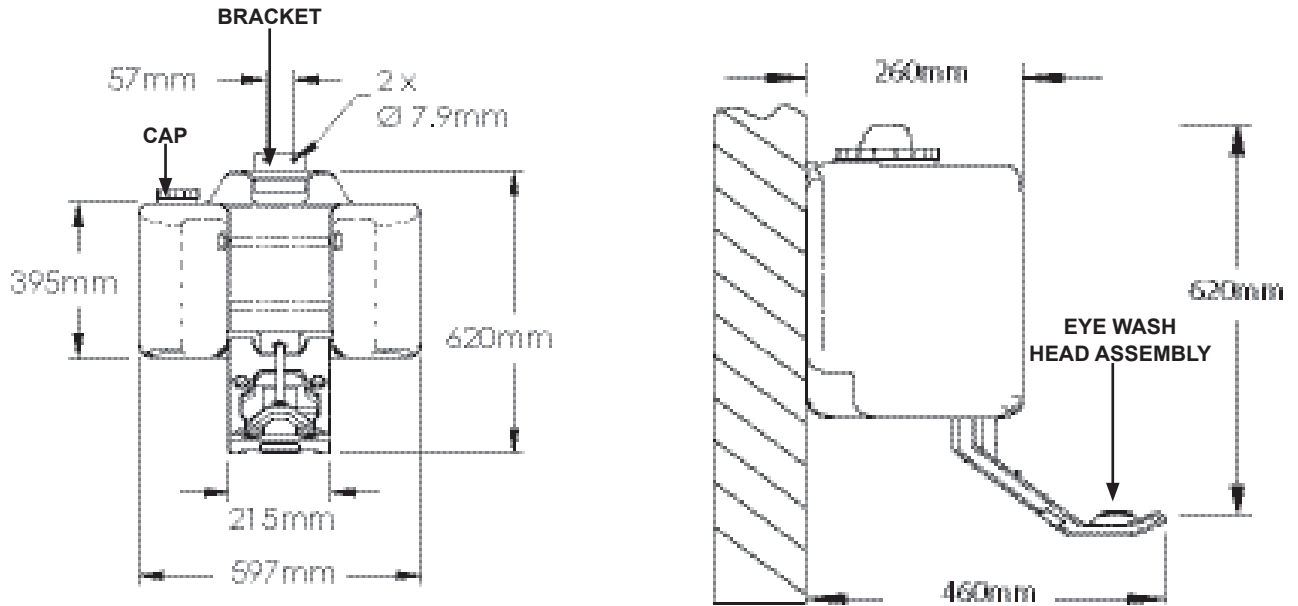

2.3 SPARE PARTS

ELS001	EL483 TANK CAP
ELS002	EL483 SPRINKLER ASSEMBLY
ELS003	EL483 SINAGE FOR PULL DOWN HANDLE
ELS004	EL483 WALL MOUNTING BRACKET
ESS200	PRESERVATIVE

3. SERVICE AND MAINTENANCE

3.1 MAINTENANCE

1. Check eyewash liquid level and temperature daily. Once every week test eyewash for 10 seconds to ensure proper flow from eyewash heads. After testing/inspection, top up tank with clean, potable water. Record weekly Testing/Inspection on test tag or separate maintenance log book (preferred).

2. Take proper precautions to help prevent the growth of potentially harmful bacteria in eyewash tanks. We recommend either of the following procedures:

a) Use suitable Bacteriostatic Preservative to help prevent the growth of bacteria in eyewash tank. Eyewash tank should be drained, flushed and refilled with clean potable water and Bacteriostatic Preservative as directed by the preservative's manufacturer.

b) Drain, flush and refill portable units with clean potable water at least once every week. Thoroughly cleanse tank at least once every month.

NOTE: Acanthamoeba survive mild chlorination and are commonly found in tap water. Bacteriostatic Preservative will prevent the growth of Acanthamoeba. Hot water 70°C or hotter will destroy Acanthamoeba, but must be allowed to cool prior to use in eyewash units.

3.2 TROUBLESHOOTING

Refer to the following troubleshooting chart for specific problems and solutions. Service instructions are supplied with spare part kits

PROBLEM	CAUSE	RECTIFICATION
No Flow	Tank empty.	Refill tank
	Obstruction in line or fitting	Clear obstruction
Poor Flow	Assembly head(s) need adjusting	Tighten head assembly head(s)
	Obstruction	If necessary, remove eye wash head(s), clean and reassemble. To reassemble head, place cap screw through head and thread into head anchor 2 or 3 turns. Tilt head assembly & work anchor legs into eye wash armholes. Tighten assembly. Check for leaks.
Water leak between joints or fittings	Hose fitting not fitted correctly or obstructed	Pull hose off fitting. Smooth raised plastic edge on centre of fitting. Return hose and hose clamp to original position
	Loose hose clamp	Tighten hose clamp(s) with pliers

4. CARE AND MAINTENANCE

Enware Product should be cleaned with a soft damp cloth using only mild liquid detergent or soap and water. Do not use cleaning agents containing a corrosive acid, scouring agent or solvent chemicals. Do not use cream cleaners, as they are abrasive. Epoxy coated surfaces should only be cleaned with a cloth and clear water or mild detergent. Use of unsuitable cleaning agents may damage the surface. Any damage caused in this way will not be covered by warranty.

5. WARRANTY

Product Warranties for Australia

Enware Australia Pty Limited (ACN 003 988 314) (“we” or “us”) warrants that this product (also referred to as “our goods”) will be free from all defects in materials and workmanship for 24 months* from the date of purchase. Our liability under this warranty is limited at our option to the repair or replacement of the defective product or part, the cost of repair of the defective product or part or the supply of an equivalent product or part, in each case if we are satisfied the loss or damage was due to a defect in the materials or workmanship of the product or part. All products must be installed in accordance with the manufacturer’s instructions, the PCA, and AS/NZS3500 including any other applicable regulatory requirements.

Making a claim

To make a claim under this warranty you must notify us in writing within 7 days of any alleged defect in the product coming to your attention and provide us with proof of your purchase of the product together with a completed Product Service Request form (ENF091), which is available on request from our office (see contact details below). All notifications and accompanying forms must be sent to us marked for the attention of the Enware Australia Pty Limited, 9 Endeavour Road, Caringbah NSW 2229. We can also be contacted by telephone (1300 369 273) or by email (info@enware.com.au). Your costs in making a claim under this warranty, including all freight, collection and delivery costs, are to be borne and paid by you. We also reserve the right at our cost to inspect any alleged defect in the product wherever it is located or installed or on our premises.

Exceptions

This warranty does not apply in respect of any damage or loss due to or arising from:

- a) Failure by you or any other person to follow any instructions for use (including instructions and directions relating to the handling, storage, installation, fitting, connection, adjustment or repair of the product) published or provided by us;
- b) Failure by you or any other person responsible for the fitting, installation or other work on the product to follow or conform to applicable laws, standards and codes (including the AS/NZ 3500 set of Standards, all applicable State and Territory Plumbing Codes, the Plumbing Code of Australia and directions and requirements of local and other statutory authorities); or
- c) Any act or circumstance beyond our control including faulty installation or connection, accident, abnormal use, acts of God, damage to buildings, other structures and infrastructure and loss or damage during transit or transportation of the product.

Other conditions

Except as provided or referred to in this document, we accept no other or further liability for any damages or loss (including indirect, consequential or economic loss) and whether arising in contract, tort or otherwise.

Any benefits available to you under this warranty are in addition to any non-excludable rights or remedies you may have under applicable legislation, including as a “consumer” under the Australian Consumer Law. To that extent you need to be aware that: Our goods come with guarantees that cannot be excluded under the Australian Consumer Law. You are entitled to a replacement or refund for a major failure and for compensation for any other reasonably foreseeable loss or damage. You are also entitled to have the goods repaired or replaced if the goods fail to be of acceptable quality and the failure does not amount to a major failure.

* 1 Year parts and labour on complete assembly. After 1 year, a further 1 year parts only warranty is applicable – Enware Safety Systems - Self Contained.

TM TM

