

FREE STANDING HAND OPERATED EMERGENCY SHOWER & PLATFORM OPERATED EYE WASH

Installation & Maintenance Instructions

EP1020



I00231_Mar 2016

NOTE: THIS DOCUMENT IS TO BE LEFT ONSITE WITH FACILITY MANAGER AFTER INSTALLATION

Call 1300 369 273

www.enware.com.au/ehs

Enware Australia Pty Limited

9 Endeavour Rd Caringbah NSW 2229 Australia

Ph: +61 2 8556 4000 Fax: +61 2 8556 4055

The logo for ENWARE, featuring three stylized blue waves to the left of the word "ENWARE" in a bold, blue, sans-serif font.

installing**confidence**

TECHNICAL INFORMATION

Inlet Connection	1" BSP (DN25mm)
Shower	Operate by pulling down on activation handle
Eyewash	Operate via spring loaded platform floor connected to ball valve
Water Supply Line Size	Supply piping shall be adequately sized to meet flow requirements
Waste Water Outlet Size	38.1 mm OD (1 ½")
Minimum Requirements to achieve ANSI Z358.1-2009 and AS4775-2007 compliance:	
Min Working Pressure	210 kPa (30 psi) Caution should be taken when pressure exceeds 550 kPa (80 psi)
Shower Minimum Flow	75.7 lpm (20 US gpm)
Eye Wash Minimum Flow	1.5 lpm (0.4 US gpm)
Eye/Face Wash Min Flow	11.4 lpm (3 US gpm)
Enware Performance: At Working Pressure 210 kPa (30 psi)	
Shower Flow	76 lpm (20 US gpm)
Eye Wash Flow	17 lpm (4.5 US gpm)
Eye/Face Wash Min Flow	26 lpm (6.9 US gpm)

For use with potable water only.

DIMENSIONS

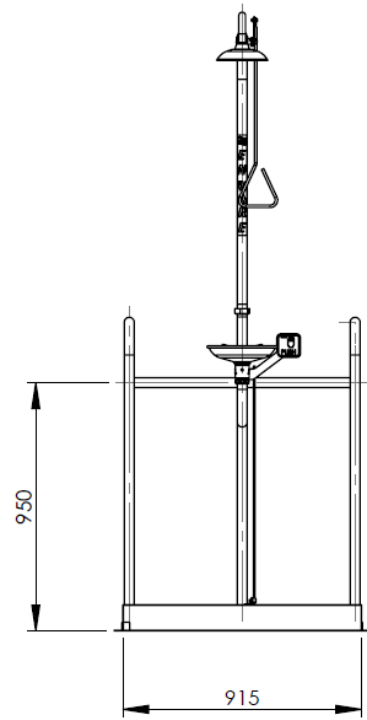
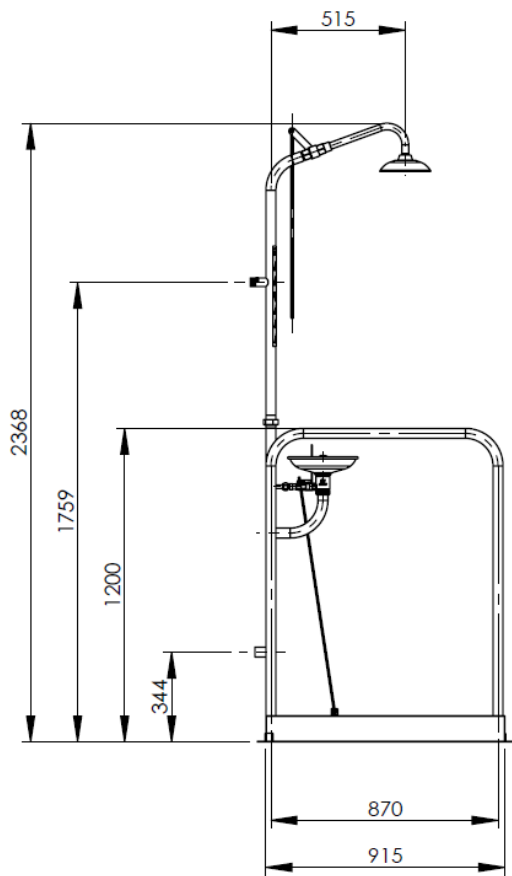
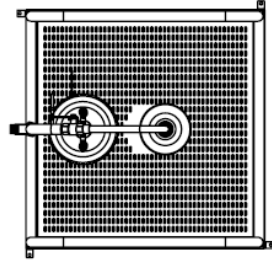

COMPONENTS

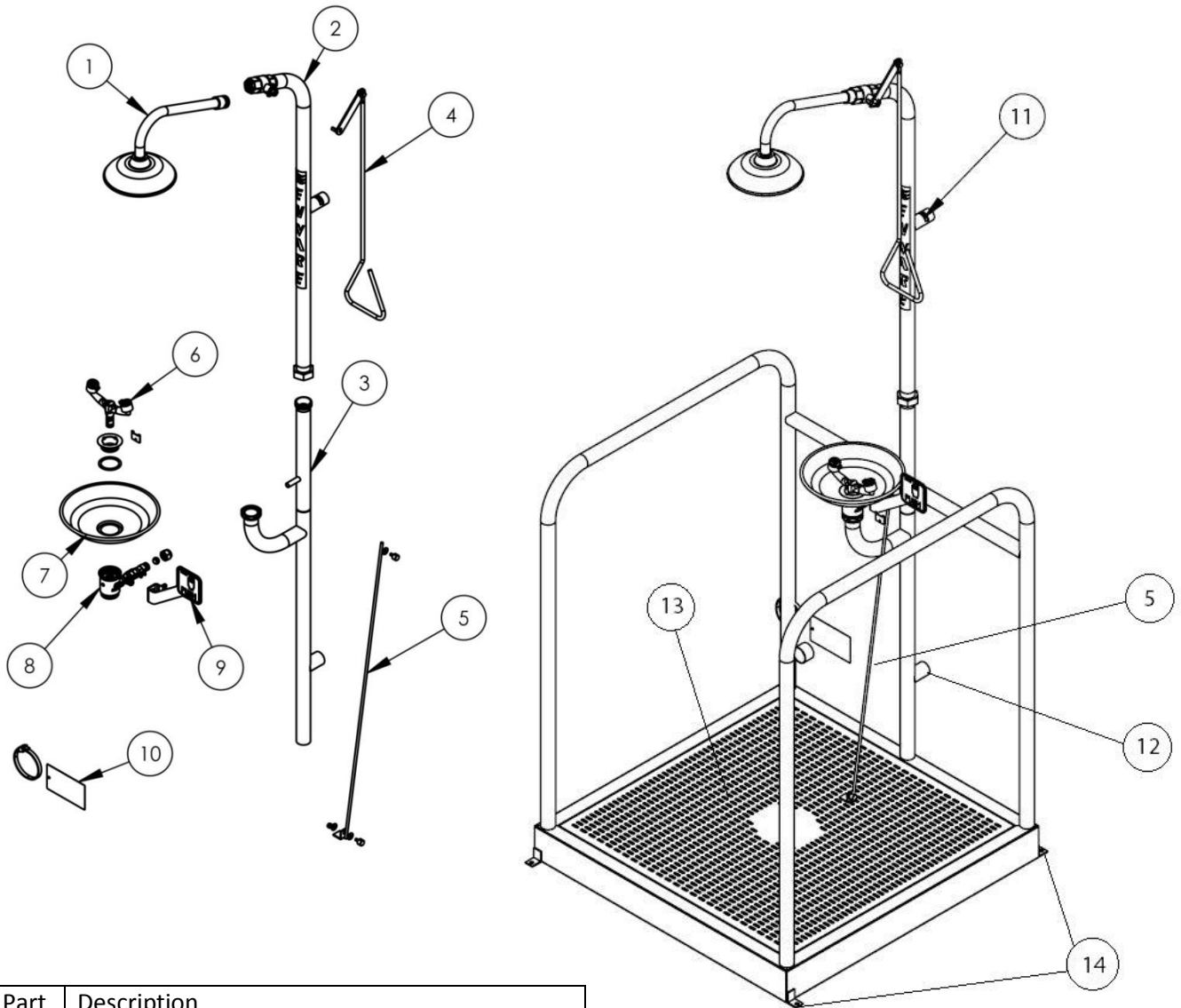

Part	Description
1	Shower arm and rose
2	Upper frame (Shower Top)
3	Lower frame (Shower Bottom)
4	Pull handle
5	Eyewash connecting rod
6	Eyewash outlet
7	Eyewash bowl
8	Eyewash waste
9	Push handle
10	Inspection tag
11	Inlet connection G 1" BSPT
12	Waste water outlet 38.1mm OD
13	Platform (spring loaded - eye wash activation)
14	Fixing lugs for bolt fixing

INSTALLATION COMPLIANCE

Installation of emergency showers, eye and eye/face wash equipment shall be in accordance with AS4775-2007 or ANSI Z358.1-2009 - whichever is applicable to the installation.

SUPPLY LINES

Installation procedures shall be in accordance with correct plumbing practices. Supply piping shall be adequately sized to meet flow requirements. If shut off valves are installed for maintenance purposes, provisions shall be made to prevent unauthorised shut off.

PLACEMENT OF EMERGENCY EQUIPMENT

Emergency eyewash and shower equipment shall be available for immediate use. It shall take no longer than 10 seconds for an individual to reach the nearest facility. Factors that influence the location of emergency facilities include workplace lighting, obstructions to the path of travel and the work environment.

It should be noted that some situations may warrant the placement of equipment significantly closer to the hazard. In these situations, such as exposure to highly corrosive chemicals, the proper distances should be selected based on the advice from appropriate consultants. For situations such as exposure to strong acids or alkalis, due consideration needs to be given to possible reaction between the flushing fluid and the chemical if the flushing fluid enters a bulk container of the chemical.

FLUSHING FLUID TEMPERATURE

Continuous and timely irrigation of affected tissues for the recommended irrigation period are the principal factors in providing first aid treatment. Providing flushing fluid at temperatures conducive to use for the recommended irrigation period is considered as an integral part of providing suitable facilities. Medical recommendations suggest a flushing fluid at tepid temperature be delivered to affected chemically-injured tissue.

Temperatures in excess of 38°C have proven to be harmful to the eyes and can enhance chemical interaction with the eyes and skin. During design and installation, the effects of exposure of pipe to sun, radiant heat or other heat sources should be considered, and suitable control measures should be introduced to avoid any risk of scalding. While cold flushing fluid temperature provide immediate cooling after chemical contact, prolonged exposure to cold fluids affects the ability to maintain adequate body temperature and can result in the premature cessation of first aid treatment.

Before emergency eyewash and shower equipment is selected, a risk assessment shall be carried out to determine the most appropriate delivery temperature for the application. Means to ensure a constant, suitable delivery temperature shall also be identified during selection, so that equipment can perform as desired once installed.

ASSEMBLY / INSTALLATION PROCEDURE

MOUNTING

1. Mark and drill holes for the platform base frame, and secure to level floor using corrosion resistant anchors. (Anchors are not supplied.)

SHOWER ASSEMBLY

2. Apply sealing tape or Loctite 577 to threaded end of shower rose assembly and screw it into the ball valve of the Upper Shower Assembly. Tighten to an aligned position where the shower head is parallel to the floor.

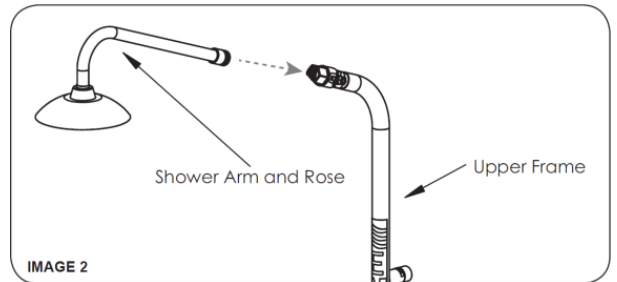

3. Attach the pull arm to the Upper Ball Valve using the nut already on the ball valve. The valve arm should point up toward the back at 45 degrees when in the off position.

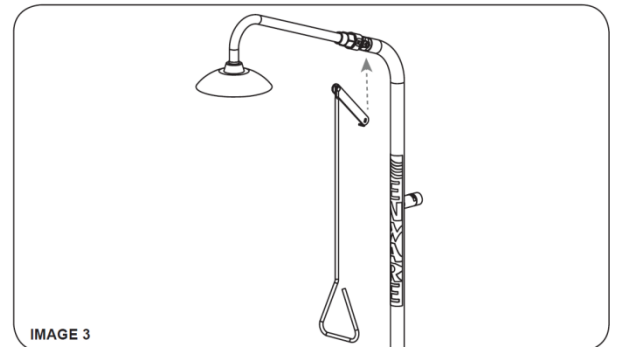

4. Connect Upper Shower Assembly to Lower Shower Assembly using the integral Stainless Steel Union. No tools are required. Be sure the rubber O-ring is in place on the tapered section of the union and tighten by hand. Check that the arm of the shower is aligned with the Eye wash.

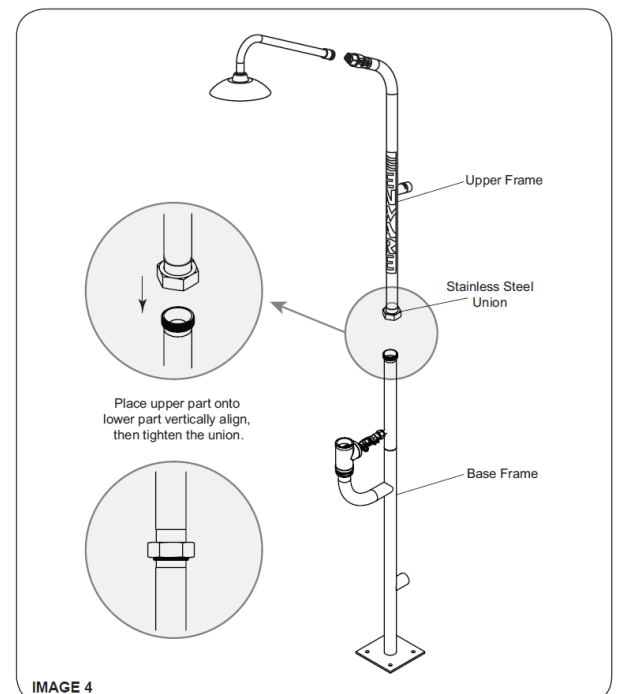

EYE WASH ASSEMBLY

5. Attach the Eye or Eyewash push handle to the Activation Ball Valve using the spring washer & hexagonal nut already on the ball valve.

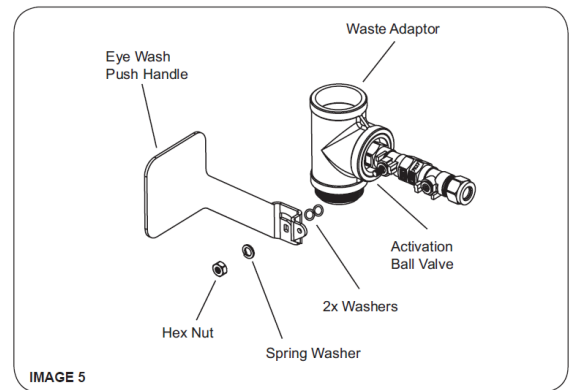

6. Place the Eye Wash Bowl on top of the Waste Adaptor. Using the Washer and the Waste – screw in to the Waste Adaptor to secure the bowl. Turn as tight as you can with fingers, then turn Waste and Bowl together using the outside edge of the bowl for extra leverage.

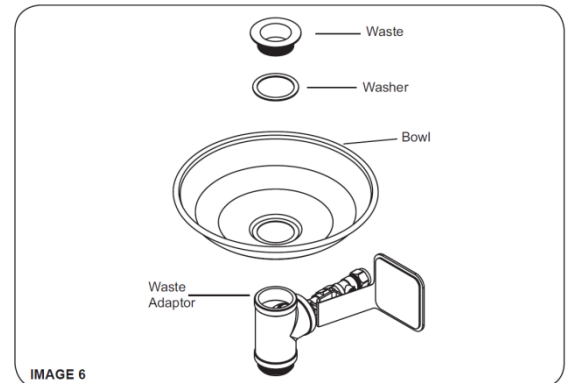

7. Remove the grub screw from the front of the waste adaptor. Push the eye wash assembly into the centre of the waste adaptor making sure the directional arrow is facing the front. Re-fit the grub screw and tighten until it locates within the eye wash frame.

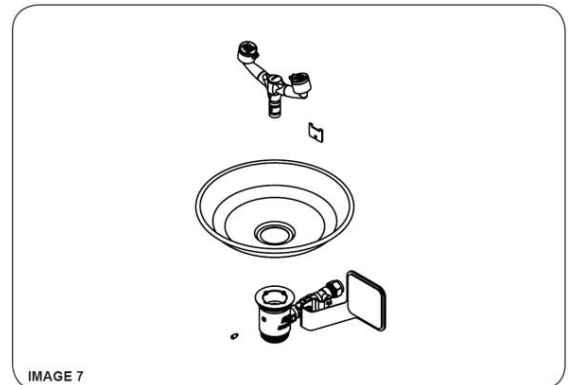

8. Connect the water supply line to the 1" thread located on the Upper Shower Assembly. Use thread tape or Loctite 577 on all threads.
9. Connect the drain line (if applicable) for the Eye Wash Sink using the 1½" OD outlet located on the Lower Shower Assembly. There should be sufficient clearance for the addition of a drain trap if required.
10. Attach connecting rod to the platform then to the remaining hole on the push handle. Adjust the position of the rod so that by stepping on the platform, the eye wash ball valve can be turned on to fully open position.

TESTING

11. Before turning on the water supply to the unit make sure both the shower and Eye wash valves are closed. Push up the shower pull rod so the valve arm is pointing back up and pull forward the Eye wash "PUSH" handle back up to ensure the valves are in the closed position.
12. Turn water supply on. Check for leaks before proceeding.

13. Slowly push the Eye wash valve handle forward to start the water flow. Flush until the water runs clean then pull back on the push handle to stop flow. Replace aerator assemblies. Remove internal strainer by unscrewing the strainer cap with a flat head screw driver. Clean strainer and re fit.

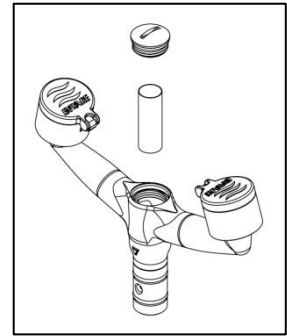

14. With the aerators reinstalled, use a flat screwdriver to turn off the Ball Valve before Eye Wash Activation Ball Valve. Turn the push handle to the full open position and adjust the second ball valve with screwdriver until the correct flow is achieved.

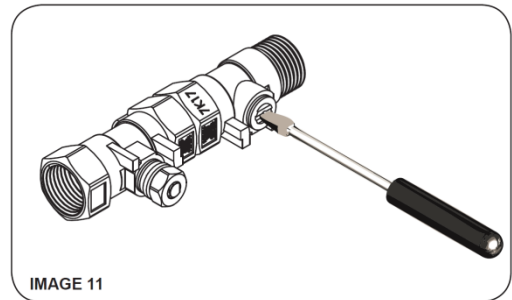

15. To activate the shower, pull down on the triangular pull rod. A large amount of water will flow from the showerhead on to the floor. The spray pattern should be 508mm in diameter at a height of 1524mm from the floor. The shower should also deliver at a minimum flow rate of 75.7 lpm.

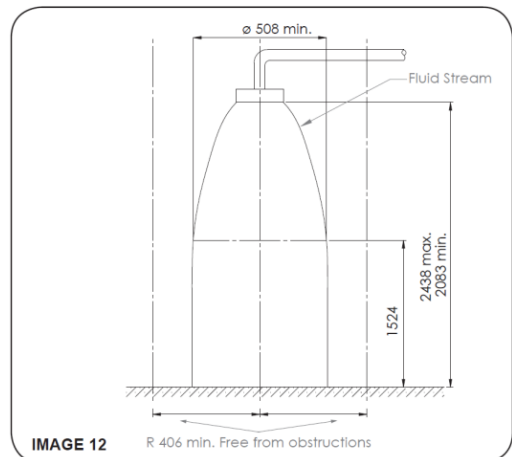
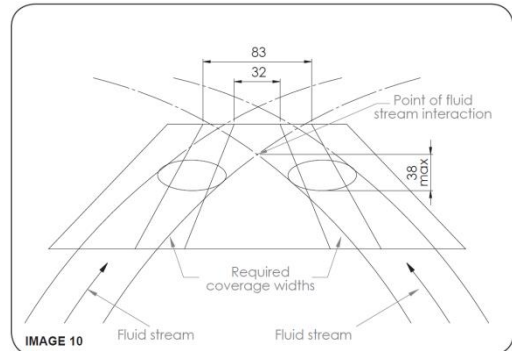

16. Once correct operation has been checked, turn off the valves by positioning the handles to the fully off position. Note: Water will drain through the 2mm hole near the shower head/ball valve connection. This is a self-draining feature designed to drain water remaining in shower head to reduce Legionella risk.
17. Place dust covers over Eyewash outlets. Mount appropriate Shower and Eye wash signage as required - refer to Enware's Product guide.

OPERATING AND TRAINING INSTRUCTIONS

Instructions for all emergency equipment shall be readily accessible to maintenance and training personnel. Employees who may be exposed to hazardous materials shall be instructed in the location and proper use of emergency shower equipment. Refer to AS4775-2007 or ANSI Z358.1 where applicable.

SHOWER OPERATION

Pulling down on the triangular pull handle activates the shower; this handle opens the 1" ball valve allowing water to flow through to showerhead.

To close the shower valve and stop flow the handle is pushed upwards. The water remaining in shower head will drain through the self-draining hole after closing the valve.

EYEWASH OPERATION

The Eyewash is activated by stepping onto the platform. This opens the 1/2" ball valve allowing water to flow to the Eyewash outlets.

To close the valve and stop the flow, simply step off the platform floor.

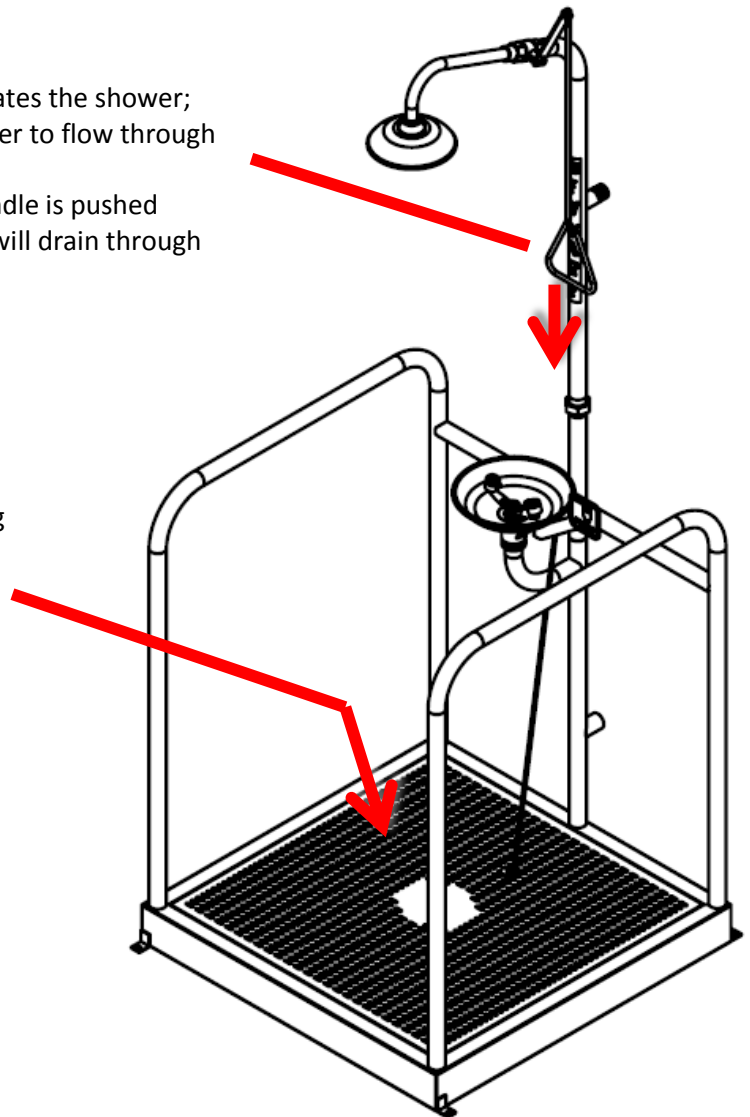

MAINTENANCE

The shower and eye wash units should be activated every week for a period long enough to verify operation and ensure the flushing fluid is available. Note: the intent is to ensure that there is a flushing fluid supply at the head of the device and to clear the supply line of any sediment build up that could prevent fluid from being delivered to the head of the device and to minimise microbial contamination due to sitting water.

All shower and eye wash units shall be inspected annually by a qualified technician to assure conformance with ANSI Z358.1-2009 or AS4775-2007, whichever is applicable to the installation.

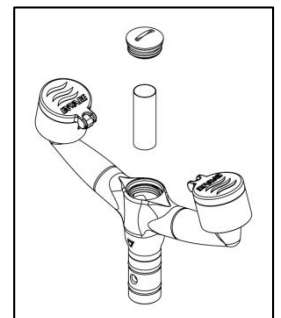

AS4775 – 2007 Safety Equipment Minimum Performance Checklist

- Installation shall be in accordance with proper plumbing practices. Supply piping shall be adequately sized to meet flow requirements. (Sec D1)
- All plumbed emergency equipment shall be connected to a continuous source of flushing fluid supply which may be drinking water, preserved water, preserved buffered saline solution or other medically acceptable solution manufactured and labelled in accordance with applicable government regulations. (Sec 4.4, 4.10, 6.7 (c)), 7.5 (b), 8.5 (b), 9.5 (b), 11.3.3 (c))
- All equipment shall be constructed of corrosion-resistant materials (Sec 4.2, 5.1) Note: The Plumbing Code of Australia does not allow the use of galvanised pipes or fittings on drinking water supply lines. AS/NZS3500.1 Sec 2.4.2(c)
- Safety equipment shall be accessible within 10 seconds of hazard. (Sec 6.6, 7.4, 8.4, 9.4)
- Safety equipment shall be located on the same level as the hazard and the path of travel shall be free of obstructions. (Sec 6.6, 7.4, 8.4, 9.4)
- Emergency equipment location shall be well illuminated and be identified by a highly visible sign complying with AS1319 visible throughout the area served by the equipment. (Sec 6.6, 7.4, 8.4, 9.4)
- Employees who may be exposed to hazardous materials shall be trained in the location and proper use of emergency equipment. (6.8, 7.6, 8.6, 9.6).
- Emergency equipment shall be activated weekly to verify operation (6.8, 7.6, 8.6, 9.6)
- Emergency equipment shall be inspected annually to ensure conformance with the requirements of AS4775. (Sec 6.8, 7.6, 8.6, 9.6)
- Combination unit components shall comply with the individual performance requirements of the shower, eye wash & eye/face wash while operating simultaneously & shall be positioned so components may be used simultaneously by the same user. (Sec 9.3, 9.5 (b), 9.5 (e) (iii))
- Drench hoses are considered supplemental equipment to provide immediate flushing to support plumbed and self-contained equipment but shall not replace them. (Sec 11.1)
- Drench hoses shall be simple to operate and shall go from closed to fully open in one second or less. The valve shall be corrosion resistant. (Sec 11.3.2)
- Showerhead shall be not less than 2083mm and not more than 2438mm from the surface on which the user stands. (Sec 6.5.1, 9.1 (b))
- Shower shall deliver a minimum of 75.7 l/min of flushing fluid at 210kPa, with the flushing fluid being substantially dispersed throughout the pattern which shall be of a minimum diameter of 508mm when measured at 1524mm above the surface on which the user stands. (Sec 6.2, 6.5, 9.1 (b), 9.3)
- The shower operating control valve shall remain open without the use of the operator's hands. The valve shall be simple to operate and shall go from closed to fully open in one second or less and not be located more than 1733mm from the surface on which the user stands. The valve shall be corrosion resistant. (Sec 6.3, 7.2, 8.2, 9)
- Eye wash equipment shall deliver flushing fluid to both eyes simultaneously at a flow rate not less than 1.5 l/min at 210kPa. The flushing fluid streams should rise to approximately equal heights and should cover the areas between the interior and exterior lines of the test gauge and when lowered not more than 38mm below the fluids peak. (Sec 7.1, 9.1 (c), 7.3.1)
- Eye / face wash equipment shall deliver flushing fluid to the eyes simultaneously at a flow rate not less than 11.4 l/min at 210kPa. The flushing fluid streams should rise to approximately equal heights and should cover the areas between the interior and exterior lines of the test gauge when lowered not more than 38mm below the fluids peak. (Sec 8.1, 8.3, 9.1 (d))
- The flushing fluid nozzles of eye and eye/face wash units shall be not less than 838mm and no greater than 1143mm from the surface on which the user stands, and 153mm from the wall or nearest obstruction. (Sec 7.4, 8.4, 9.1 (c), 9.1 (d))
- The eye and eye/face wash operating control valve shall remain open without the use of the operator's hands. The valve shall be simple to operate and go from closed to fully open in one second or less. The valve shall be corrosion resistant. (Sec 7.2, 8.2, 9.1 (c), 9.1 (d))

ANSI Z358.1 – 2009 Safety Equipment Minimum Performance Checklist

RECOMMENDED TESTING FLOW PRESSURE IS 30 psi (+.5 psi -.0 psi)

- Safety equipment shall be accessible within 10 seconds of hazard. (Sec 4.5.2, 5.4.2, 6.4.2, 7.4.2)
- Safety equipment shall be located on the same level as the hazard and the path of travel shall be free of obstructions. (Sec 4.5.2, 5.4.2, 6.4.2, 7.4.2)
- All employees subject to exposure to hazardous material should be instructed in the location and proper use of emergency equipment. (Sec 4.6.4, 5.5.4, 6.5.4, 7.5.4)
- Emergency equipment shall be activated weekly. (Sec. 4.6.2, 5.5.2, 6.5.2, 7.5.2) All shower units shall be inspected annually to assure conformance with ANSI Z358.1. (Sec. 4.6.5, 5.5.5, 6.5.5, 7.5.5)
- Combination unit components shall be capable of operating simultaneously and shall be positioned so that components may be used simultaneously by the same user. (Sec. 7.3, 7.4.4)
- All plumbed emergency equipment shall be connected to a continuous source of flushing fluid supply which may be drinking water, preserved water, preserved buffered saline solution or other medically acceptable solution manufactured and labelled in accordance with applicable government regulations.
- Drench hose must deliver a controlled flow of flushing fluid at a velocity low enough to be non-injurious. (Sec. 8.2.1)
- A drench hose can only be considered an eyewash – eye/face wash if it meets performance requirements in Sec. 5 and/or 6.
- Delivery of tepid flushing fluid.* (Sec. 4.5.6, 5.4.6, 6.4.6, 7.4.5). ***Suggested temperature range – above 60°F (16°C) and below 100°F (38°C)**
- Showerhead must be 82 to 96 inches (208.3cm – 243.8cm) above surface floor of user (Sec. 4.1.3, 7.1)
- Shower must deliver minimum of 20 gallons (75.7L) per minute and provide a column of water 20 inches (50.5cm) wide at 60 inches (152.4cm)
- Valve shall be designed so that the flushing flow remains on without the use of the operator’s hands. The valve shall be simple to operate and go from “off” to “on” in one second or less and actuator can not be more than 69 inches (173.3cm) from surface floor of user. (Sec. 4.2, 7.1)
- Emergency equipment location shall be well lit and identified with a highly visible sign. (Sec. 4.5.3, 5.4.3, 6.4.3, 7.4.3)
- Must provide a means of controlled flow to both eyes simultaneously at a velocity low enough to be non-injurious. (Sec. 5.1.1, 6.1.1, 7.1)
- Eye/face wash equipment must deliver minimum of 3 gallons (11.4L) per minute of water for 15 minutes. (Sec. 6.1.6, 7.1) Eyewash only must deliver minimum of 0.4 gallon (1.5L) per minute for 15 minutes. (Sec. 5.1.6, 7.1)
- The flushing fluid of an eyewash – eye/face wash shall cover the areas between the interior and exterior lines of a gauge at some point less than 8 inches (20.3cm) above the eyewash nozzle. (Sec. 5.1.8, 6.1.8, 7.1)
- Outlets shall be protected from airborne contaminants. (Sec. 5.1.3, 6.1.3, 7.1)
- Flushing fluid nozzles should be 33 to 45 inches (83.8cm – 114.3cm) from floor and minimum of 6 inches (15.3cm) from wall. (Sec. 5.4.4, 6.4.4, 7.1)
- Valve shall be designed so that the flushing flow remains on without the use of the operator’s hands. The valve shall be simple to operate and go from “off” to “on” in one second or less. (Sec. 5.2, 6.2, 7.2)



ADDRESS: 9 Endeavour Road, Caringbah NSW 2229 Australia

POSTAL ADDRESS: P.O. Box 2545, Taren Point NSW 2229 Australia

PHONE: 61 2 8536 4000 **FAX:** 61 2 8556 4066

1300 369 273 (AUS) WWW.ENWARE.COM.AU INFO@ENWARE.COM.AU

