

INSTALLATION HANDBOOK

FROGLINE HORIZONTAL LIFELINE: Installation to Steel

SafetyLink is an innovative anchor company achieving success and keeping you safe whilst working at heights.

- 📍 ROOF ANCHORS
- 📍 HORIZONTAL LIFELINES
- 📍 PERMANENT LADDERS
- 📍 LADDER STABILIZERS
- 📍 TEMPORARY ANCHOR



Read entire handbook before installing SafetyLink products. All products must be installed in accordance with SafetyLink's installation handbook, using only products supplied by SafetyLink Pty Ltd. Failure to follow all warnings and instructions may result in a serious injury or death.



SafetyLink Pty Ltd
AU: 1300 789 545
INT: +61 2 4964 1068
FAX: +61 2 4964 1069
info@safetylink.com

www.safetylink.com

INSTALLATION OF A SAFETYLINK FROGLINE HORIZONTAL LIFELINE TO STEEL

WARNINGS	3
MAINTENANCE – PERIODIC INSPECTIONS	4
WARRANTIES	5
FROGLINE STEEL – END ASSEMBLY	6
COMPONENTS	6
ASSEMBLING & INSTALLATION	7
INSPECT THE STEEL FOR STRENGTH	7
LOCATING THE PURLIN	7
ASSEMBLING & INSTALLATION CONTINUED	8
FROGLINE STEEL – INTERMEDIATE ASSEMBLY	9
COMPONENTS	9
ASSEMBLING & INSTALLATION	10
INSPECT THE STEEL FOR STRENGTH	10
LOCATING THE PURLIN	10
ASSEMBLING & INSTALLATION CONTINUED	11
FROGLINE STEEL – CORNER ASSEMBLY	12
COMPONENTS	12
ASSEMBLING & INSTALLATION	13
INSPECT THE STEEL FOR STRENGTH	13
LOCATING THE PURLIN	13
ASSEMBLING & INSTALLATION CONTINUED	14
LIFELINE SYSTEM INFORMATION	15
INSTALLATION: HORIZONTALLY ON ROOF PITCHES BELOW 25 DEGREES	15
TIGHTENING ASSEMBLY & TORQUE SETTINGS FOR SWAGELESS TERMINALS	15
APPENDIX A – SWAGELESS/SWAGED FITTINGS	16
APPENDIX A – CRIMPED FITTINGS	17
FROGLINE SHUTTLE	18
CONNECTING TO THE LIFE LINE SYSTEM	18
PROGRESSING ALONG THE LIFE LINE SYSTEM	18
DISCONNECTING FROM THE LIFE LINE SYSTEM	18
EXAMPLE: LAYOUT OF LIFELINE SYSTEM	19
IN CASE OF ACCIDENT	20



FROGLINE VIDEO



FROGLINE
INSTALLATION GUIDE



FROGLINE CATALOGUE

WARNINGS

READ CAREFULLY SOMEONE'S LIFE DEPENDS ON IT

- 🔍 The building or structure for the anchorages should be assessed by an engineer, unless it is clear to a competent person that the structure is adequate.
- 🔍 SafetyLink Height Safety Systems must only be installed as per our installation guides, to structures as specified in the installation manual for each product.
- 🔍 All safety procedures must be complied with in accordance with the current safety code(s) of practice(s) for working at heights. Ensure safety at all times by being attached to suitable anchor points and approved safety equipment or approved scaffolding.
- 🔍 Installation is to be carried out by, or under the supervision of a competent person.
- 🔍 To prevent galling of non-permanent or adjustable stainless steel components use nickel anti-seize or similar boundary layer lubricant.
- 🔍 Recommended waterproofing for roof tiles: *Sika Flex Co-Polymer Sealant*.
- 🔍 Recommended waterproofing for metal roof: *Silicone Sealant Neutral Cure*.
- 🔍 Recommended chemical anchor: Hilti RE500 or Hilti HY200 as per Hilti Product Supplement Data sheets.
- 🔍 All bolt threads must be applied with Loctite 243 thread-locker prior to assembly. (IMPORTANT NOTE: Before applying Loctite 243 use Loctite 7471 primer to activate the surface according to manufacturer's instructions).
- 🔍 A personal energy absorber or a fall-arrest device with a personal energy absorber must be used in conjunction with all SafetyLink Anchorages and Lifeline systems.
- 🔍 SafetyLink Horizontal Lifelines must be installed to roofs pitches no greater than 25 degrees.

WARNING: Surface Mounted Anchors should be positioned no less than 2 metres from the edge on KlipLok roofs.

- ⚠️ **Maximum number of users per system is Four (4).**
- ⚠️ **Maximum number of persons per span is Two (2).**
- ⚠️ **See system information for site specific use.**

MAINTENANCE – PERIODIC INSPECTIONS

All items of equipment which are in regular use shall be subjected to periodic inspection and servicing.

These regular scheduled inspections and servicing must be carried out by a competent person (*refer to AS/NZS 1891.4:2009 if clarification required or contact SafetyLink*).

SafetyLink Anchorages (*In accordance with AS/NZS 1891.4:2009*)

ALL ANCHORAGES MUST BE INSPECTED EVERY 12 MONTHS.

Procedures to be followed at inspection time:

- Visually inspect anchors for signs of deterioration.
- The FrogLine End, Intermediate and Corner anchor points have energy absorbing regions and stabilising joints. If these energy absorbing regions are expanded this will indicate the anchor point has arrested a fall and should be replaced. Similarly if the stabilising joints have been broken this would also indicate the anchor point has arrested a fall and should be replaced. (*The design features of the FrogLine's curved profile provides the initial shock absorbing capabilities in the event of a fall. Further extension is provided in the serpentine shapes which progressively dissipate and absorb energy whilst retaining their strength. This lessens the force on the person falling and the structure the anchor is attached to.*)
- Visually inspect the components of the anchor for corrosion, superficial surface marking is permitted while deeper corrosion or pitting would require attention.
- Manually (by hand) check the 16mm Bolts securing the FrogLine Base to the 16mm Nut and Washer for rigidity and tightness. If the Bolt can turn in the anticlockwise direction it will require attention.
- Visually inspect the attachment component of the anchorage where practically possible.
- Visually inspect the parent structure for modifications or deterioration which might lead to loss of anchorage strength.
- Check the full length of the stainless steel cable for any evidence of wear, cuts, looseness, extension, inter-strand wear, corrosion, stiffness, brittleness or fraying.
- Check the integrity of cable terminations and that life line tensioners are correctly adjusted (80kg/8kn/800n) and lock nuts are tensioned correctly.
- Check for the presence of contaminants or exposure to a corrosive or extreme environment signs may include discoloration, crystallising or oxidation. These could significantly reduce the safe working load of the Lifeline.
- Run the FrogLine Shuttle along the full length of the life line to verify its correct function.

IN ADDITION TO SAFETYLINK PTY LTD EQUIPMENT, ALL ANCILLARY EQUIPMENT MUST BE INSPECTED IN ACCORDANCE WITH APPLICABLE REGULATORY REQUIREMENTS AND THE MANUFACTURER'S INSTRUCTIONS.



**FOR MAINTENANCE ADVICE AND SERVICES PLEASE CONTACT SAFETYLINK
ON +61 249 641068 OR 1300 789545 FOR YOUR NEAREST SAFETYLINK INSPECTION SERVICE CENTRE
OR EMAIL: info@safetylink.com**

WARRANTIES

EXTRACT: SafetyLink Pty Ltd STANDARD TERMS AND CONDITIONS

- 11.1 To the extent permitted by law all implied conditions, warranties and undertakings are expressly excluded.
- 11.2 Except as provided in this clause the Company shall not be liable for any loss or damage, whether direct or indirect (including consequential losses or damage) arising out of any breach of contract by the Company or any negligence of the Company, its employees or agents.
- 11.3 Should the Company be liable for a breach of a guarantee, condition or warranty implied by the Australian Consumer Law (not being a guarantee, condition or warranty implied by sections 51, 52 and 53 of that Law) then its liability for a breach of any such condition or warranty express or implied shall be limited, at its option, to any one or more of the following.
- A) in case of Goods
 - (I) the replacement of the Goods or the supply of equivalent Goods.
 - (II) the repair of the goods,
 - (III) the payment of the cost of replacing the Goods or acquiring equivalent Goods.
 - (IV) The payment of the cost of having the Goods repaired.
Provided that any such Goods are returned to the Company by the Purchaser at the Purchaser's expense.
 - B) in the case of services
 - (i) the supply of the services again,
 - (ii) the payment of the cost of having the services supplies again.
- 11.4 The Company will not liable for the costs of recovery of the Goods from the field, loss of use of the Goods, loss of time, inconvenience, incidental or consequential loss or damage, nor for any other loss or damage of her than as stated above, whether ordinary or exemplary, caused either directly or indirectly by use of the Goods.
- 11.5 The Company warrants that at the time of shipment, Products manufactured by it will be free from defects in material and workmanship. In the absence of a modified written warranty, the Company agrees to making good any such defects by repairing the same or at the Company 's option by replacement, for a period of (1) one year from the date of shipment. This limited warranty applies provided that:
- (a) defects have arising solely from faulty materials or workmanship;
 - (b) the Products have not received maltreatment, inattention or interference;
 - (c) **the Products have been installed in accordance with the Company's Installation Handbooks using only products supplied by the Company;**
 - (d) accessories used with the Products are manufactured by or approved by the Company ;
 - (e) the Products are maintained in accordance with Australian Standard 1891.4 (section 9).
 - (f) you notify any claim under this warranty to SafetyLink in writing to the address below no later than 14 days after the event or occurrence concerning the produce giving rise to the claim and you pay all costs related to your claim.

This warranty does not apply to any defects or other malfunctions caused to the Goods by accident, neglect, vandalism, misuse, alteration, modification or unusual physical, environment or electrical stress.

Please note that the benefits to the purchaser (as a consumer) given by this warranty are in addition to your other rights and remedies under the Australian Consumer Law. Our goods come with guarantees that cannot be excluded under the Australian Consumer Law. You are entitled to a replacement or refund for a major failure and compensation for any other reasonably foreseeable loss or damage. You are also entitled to have the goods repaired or replaced if the goods fail to be of acceptable quality and the failure does not amount to a major failure.

- 11.6 If any goods are not manufactured by the Company, the guarantee of the manufacturer thereof shall be accepted by the Purchaser as the only express warranty given in respect of the goods.
- 11.7 Except as provided in this clause 11, all express and implied warranties, guarantees and conditions under statute or general law as the merchantability, description, quality, suitability or fitness of the Products for any purpose or as to design, assembly, installation, materials or workmanship or otherwise are hereby expressly excluded (to the extent to which they may be excluded by law).

PLEASE SEE SAFETYLINK PTY LTD FULL STANDARD TERMS OF CONDITIONS OF SALE FOR FURTHER REFERENCE.

INSTALLATION OF A SAFETYLINK HORIZONTAL LIFELINE SYSTEM USING FROGLINE ON STEEL PURLINS PITCHES BELOW 25 DEGREES

COMPONENTS

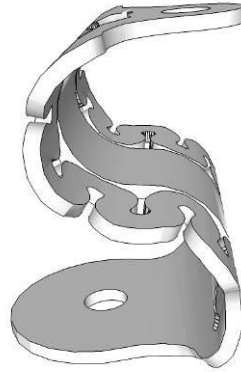

FrogLine Base



Bolt M16 x 50mm 316 Stainless Steel Set Screw

NOTE: All bolt threads must be applied with Loctite 243 thread-locker prior to assembly. (IMPORTANT NOTE: Before applying Loctite 243 use Loctite 7471 primer to activate the surface according to manufacturer's instructions).



M16 Washer



M16 Nut

Recommended waterproofing for metal roof: Silicone Sealant Neutral Cure.

SETTING OUT: STEEL PURLIN PITCH BELOW 25 DEGREES

INSPECT THE INTEGRITY OF THE STRUCTURE AND ROOF SHEETING

Installation of anchors can only be made to roof structures strong enough to support the anchor point. Inspect how well the steel purlin is secured to the structure. Minimum steel purlin gauge 1.2mm. Roof sheets must be inspected thoroughly for splits, rust and corrosion damage. Ensure the roof sheeting and structure is secured in accordance with current Australian Building Codes. FrogLine Intermediate anchors must only be spaced at a maximum of 10 metres apart.

⚠ If any doubt exists as to the strength of the structure an engineer should make the assessment.

ASSEMBLING & INSTALLATION

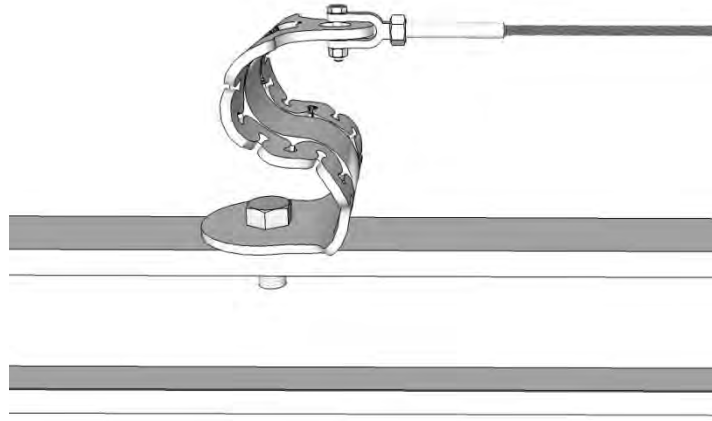

INSPECT THE STEEL FOR STRENGTH

Inspect how well the steel purlin is secured to the structure. Minimum steel purlin gauge 1.2mm.

⚠ If any doubt exists as to the strength of the structure an engineer should make the assessment.

LOCATING THE PURLIN

If the roof is screwed through the roof sheets simply follow the screws. If the roof sheeting has concealed fixings, finding the purlin is more difficult. You can lift a sheet to find the purlin or by walking on the roof you can feel the purlin. You can also use a strong magnet to find the purlin.

⚠ During installation you must be safe at all times.

STEP 1

Locate the centre of the purlin and drill a 25mm hole.

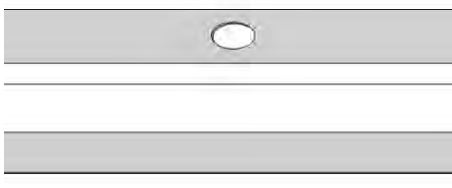

STEP 2

Place FrogLine Base on top of the hole.

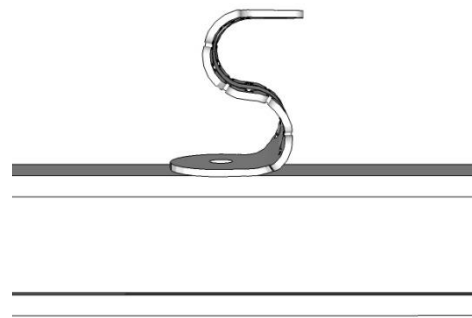

ASSEMBLING & INSTALLATION CONTINUED

STEP 3

Apply Loctite 243 to 50mm bolt thread. Screw M16 x 50mm Bolt through FrogLine End Base into the M16 Washer and M16 Nut.

(IMPORTANT NOTE: Before applying Loctite 243 use Loctite 7471 primer to activate the surface according to manufacturer's instructions).

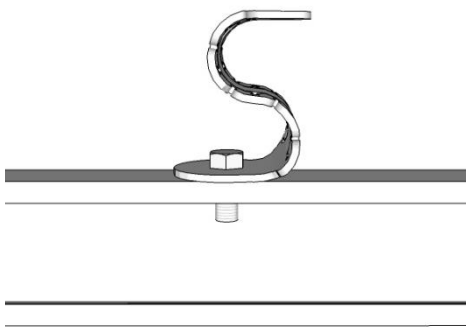

STEP 4 - Continued (perspective view)

Tighten the Bolt making certain the FrogLine End Base Unit lines up with the intended direction of the life line.

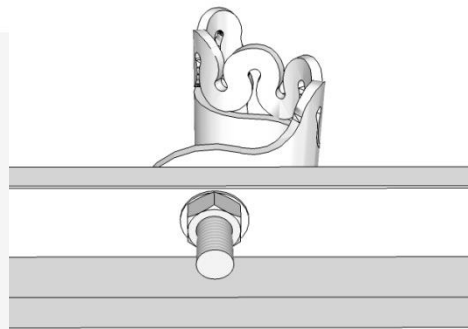

Note: Threads need to have a minimum of **nine full 360° turns** into the ultimate thread.

(IMPORTANT NOTE: Before applying Loctite 243 use Loctite 7471 primer® to activate the surface according to manufacturer's instructions).

FROGLINE INTERMEDIATE ANCHORS MUST ONLY BE SPACED AT A MAXIMUM OF 10 METRES APART.

- ⚠** If any doubt exists as to the strength of the structure an engineer should make the assessment.
- ⚠** During installation you must be safe at all times.

INSTALLATION OF A SAFETYLINK HORIZONTAL LIFELINE SYSTEM USING FROGLINE ON STEEL PURLINS PITCHES BELOW 25 DEGREES

COMPONENTS

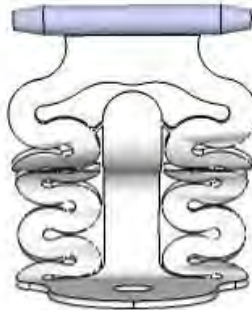

FrogLine Intermediate Base



Bolt M16 x 50mm 316 Stainless Steel Set Screw

NOTE: All bolt threads must be applied with Loctite 243 thread-locker prior to assembly. (IMPORTANT NOTE: Before applying Loctite 243 use Loctite 7471 primer to activate the surface according to manufacturer's instructions).



M16 Washer



M16 Nut

Recommended waterproofing for metal roof: Silicone Sealant Neutral Cure.

SETTING OUT: STEEL PURLIN PITCH BELOW 25 DEGREES

INSPECT THE INTERGRITY OF THE STRUCTURE AND ROOF SHEETING

Installation of anchors can only be made to roof structures strong enough to support the anchor point. Inspect how well the steel purlin is secured to the structure. Minimum steel purlin gauge 1.2mm. Roof sheets must be inspected thoroughly for splits, rust and corrosion damage. Ensure the roof sheeting and structure is secured in accordance with current Australian Building Codes. FrogLine Intermediate anchors must only be spaced at a maximum of 10 metres apart.

⚠ If any doubt exists as to the strength of the structure an engineer should make the assessment.

ASSEMBLING & INSTALLATION

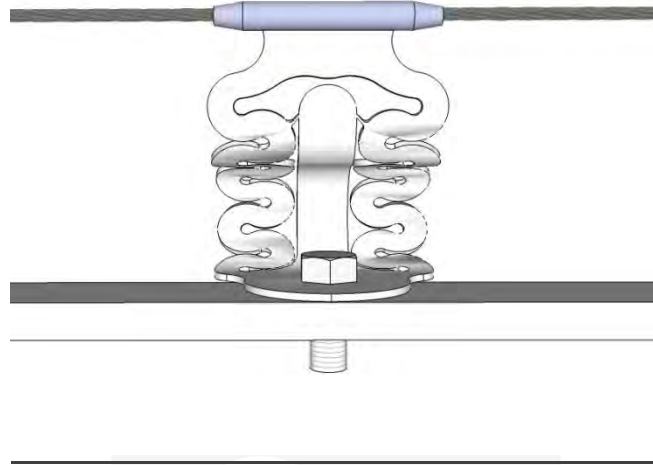

INSPECT THE STEEL FOR STRENGTH

Inspect how well the steel purlin is secured to the structure. Minimum steel purlin gauge 1.2mm.

⚠ If any doubt exists as to the strength of the structure an engineer should make the assessment.

LOCATING THE PURLIN

If the roof is screwed through the roof sheets simply follow the screws. If the roof sheeting has concealed fixings, finding the purlin is more difficult. You can lift a sheet to find the purlin or by walking on the roof you can feel the purlin. You can also use a strong magnet to find the purlin.

⚠ During installation you must be safe at all times.

STEP 1

Locate the centre of the purlin and drill a 25mm hole.

STEP 2

Place FrogLine Base on top of the hole.

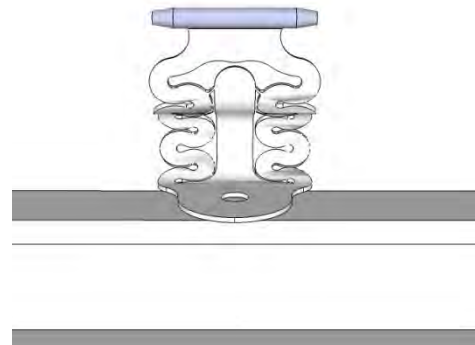
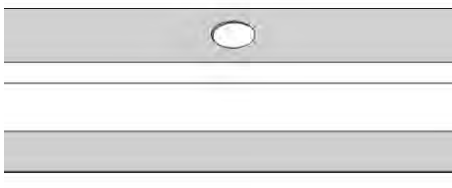

ASSEMBLING & INSTALLATION CONTINUED

STEP 3

Apply Loctite 243 to 50mm bolt thread.
Screw M16 x 50mm Bolt through FrogLine Intermediate Base into the M16 Washer and M16 Nut.

(IMPORTANT NOTE: Before applying Loctite 243 use Loctite 7471 primer to activate the surface according to manufacturer's instructions).

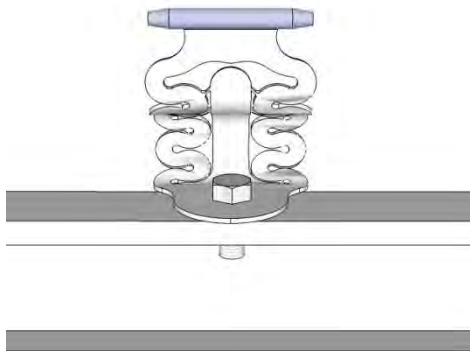

STEP 4 - Continued (perspective view)

Tighten the Bolt making certain the FrogLine Intermediate Base Unit lines up with the intended direction of the life line.

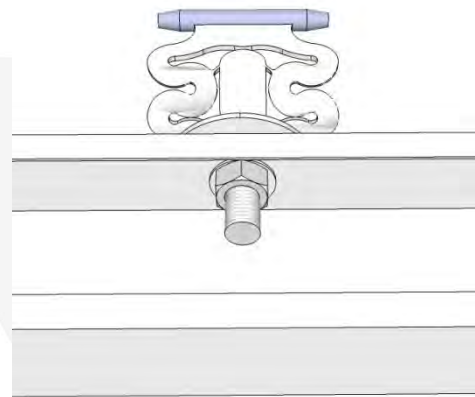

Note: Threads need to have a minimum of **nine full 360° turns** into the ultimate thread.

(IMPORTANT NOTE: Before applying Loctite 243 use Loctite 7471 primer to activate the surface according to manufacturer's instructions).

FROGLINE INTERMEDIATE ANCHORS MUST ONLY BE SPACED AT A MAXIMUM OF 10 METRES APART.

- ⚠ If any doubt exists as to the strength of the structure an engineer should make the assessment.**
- ⚠ During installation you must be safe at all times.**

INSTALLATION OF A SAFETYLINK HORIZONTAL LIFELINE SYSTEM USING FROGLINE ON STEEL PURLINS PITCHES BELOW 25 DEGREES

COMPONENTS

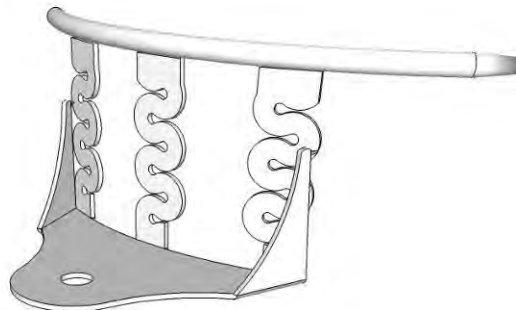

FrogLine Corner Base



Bolt M16 x 50mm 316 Stainless Steel Set Screw

NOTE: All bolt threads must be applied with Loctite 243 thread-locker prior to assembly. (IMPORTANT NOTE: Before applying Loctite 243 use Loctite 7471 primer to activate the surface according to manufacturer's instructions).



M16 Washer



M16 Nut

Recommended waterproofing for metal roof: Silicone Sealant Neutral Cure.

SETTING OUT: STEEL PURLIN PITCH BELOW 25 DEGREES

INSPECT THE INTERGRITY OF THE STRUCTURE AND ROOF SHEETING

Installation of anchors can only be made to roof structures strong enough to support the anchor point. Inspect how well the steel purlin is secured to the structure. Minimum steel purlin gauge 1.2mm. Roof sheets must be inspected thoroughly for splits, rust and corrosion damage. Ensure the roof sheeting and structure is secured in accordance with current Australian Building Codes. FrogLine Intermediate anchors must only be spaced at a maximum of 10 metres apart.

⚠ If any doubt exists as to the strength of the structure an engineer should make the assessment.

ASSEMBLING & INSTALLATION

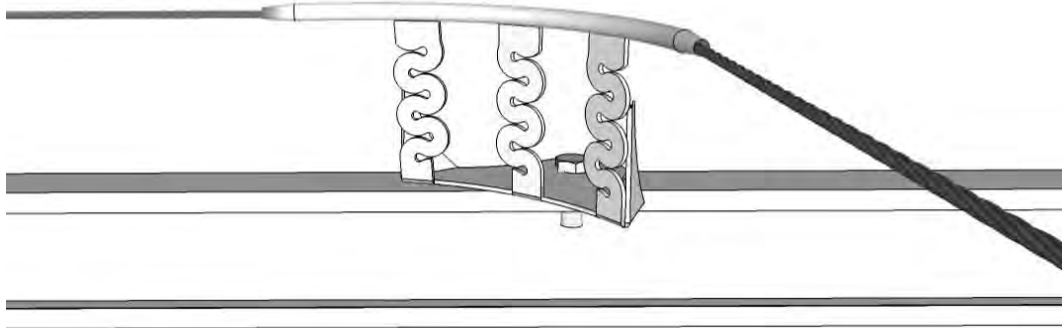

INSPECT THE STEEL FOR STRENGTH

Inspect how well the steel purlin is secured to the structure. Minimum steel purlin gauge 1.2mm.

⚠ If any doubt exists as to the strength of the structure an engineer should make the assessment.

LOCATING THE PURLIN

If the roof is screwed through the roof sheets simply follow the screws. If the roof sheeting has concealed fixings, finding the purlin is more difficult. You can lift a sheet to find the purlin or by walking on the roof you can feel the purlin. You can also use a strong magnet to find the purlin.

⚠ During installation you must be safe at all times.

STEP 1

Locate the centre of the purlin and drill a 25mm hole.

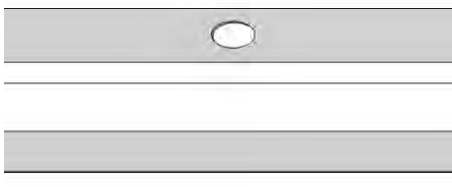

STEP 2

Place FrogLine Base on top of the hole.

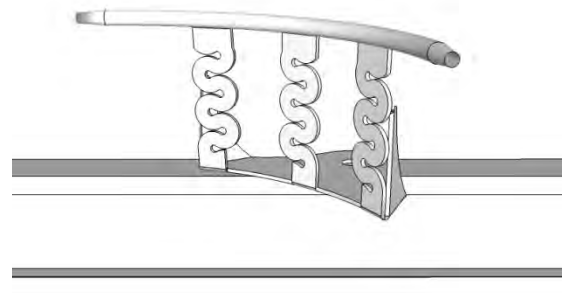

ASSEMBLING & INSTALLATION CONTINUED

STEP 3

Apply Loctite 243 to 50mm bolt thread.
Screw M16 x 50mm Bolt through FrogLine Corner Base into the M16 Washer and M16 Nut.

(IMPORTANT NOTE: Before applying Loctite 243 use Loctite 7471 primer to activate the surface according to manufacturer's instructions).

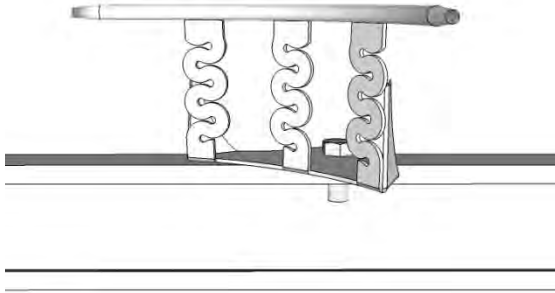

STEP 3 - Continued (perspective view)

Tighten the Bolt making certain the FrogLine Corner Base Unit lines up with the intended direction of the life line.

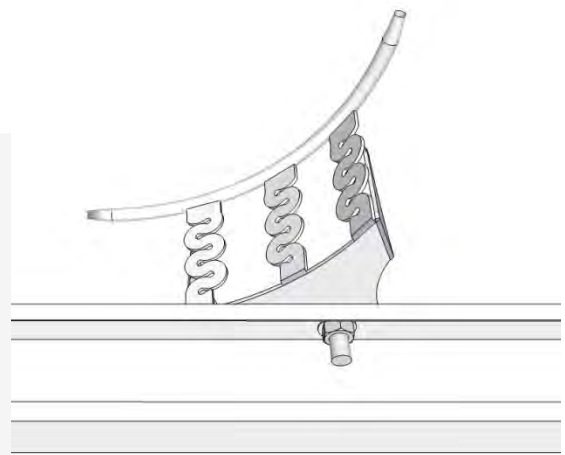

Note: Threads need to have a minimum of **nine full 360° turns** into the ultimate thread.

(IMPORTANT NOTE: Before applying Loctite 243 use Loctite 7471 primer to activate the surface according to manufacturer's instructions).

FROGLINE INTERMEDIATE ANCHORS MUST ONLY BE SPACED AT A MAXIMUM OF 10 METRES APART.

- ⚠** If any doubt exists as to the strength of the structure an engineer should make the assessment.
- ⚠** During installation you must be safe at all times.

LIFELINE SYSTEM INFORMATION

INSTALLATION: HORIZONTALLY ON ROOF PITCHES BELOW 25 DEGREES

1. Install *Swaged/Swageless Termination* to the cable in accordance with product guidelines. See [Appendix A](#).
2. Determine which end is most suitable to have the cable *Tensioner with Tension Indicator*. (Some lifelines may require a *Tensioner with Tension Indicator* on both ends). Connect the cable with *Termination* end to the *FrogLine End Anchor* top connection point. This will be at the opposite end to where the *Tensioner* end will be. (Ensure securing pin has been installed correctly).
3. Run the cable through *Intermediates* and *Corners* to the opposite end of the Lifeline system (Intermediates must be installed as per installation manual, **maximum distance between Intermediates is 10 metres**).
4. Connect *Swaged/Swageless Tensioner with Tension Indicator* to *FrogLine End Anchor* top connection point. (Do not attach *Tensioner* to cable at this stage).
5. Adjust the *Tensioner* out to the maximum safe length.
6. Match the cable along the side of the *Tensioner* and mark where to cut cable so that it will reach safely in to the *Tensioner* unit in accordance with product guidelines. [Appendix A](#).
7. Cut cable to length.
8. Install *Swage/Swageless Tensioner* fitting to cable as per [Appendix A](#). Connect *Tensioner* to *FrogLine End Anchor* top connection point (Ensure securing pin has been installed correctly).
9. Tension cable until the disc on the Tension Indicator can spin and indicates 80kg/8kn/800n.

COMPLETE LAYOUT DIAGRAM

TIGHTENING ASSEMBLY & TORQUE SETTINGS FOR SWAGELESS TERMINALS

Wire size:		Nm	Lbf ft
Ø 3	-	11	8.25
-	1/8"	11	8.25
Ø 4	5/32"	17	12.75
-	3/16"	22	16.5
Ø 5	-	22	16.5
-	7/32"	38	28.5
Ø 6	-	38	28.5
-	1/4"	38	28.5
Ø 7	9/32"	48	35.5
Ø 8	5/16"	58	43.0
-	3/8"	75	55.5
Ø 10	-	75	55.5
Ø 12	-		
-	1/2"		
Ø 14	-		
Ø 16	-		

APPENDIX A – SWAGELESS/SWAGED FITTINGS

INSTALLATION



BLUE WAVE[®]

Swageless SS Terminal 8mm 7x7, 7x19



Jaw housing
Hauptstück



Jaws
Backen



Brass Ring
Messing Ring



Head
Kopfteil

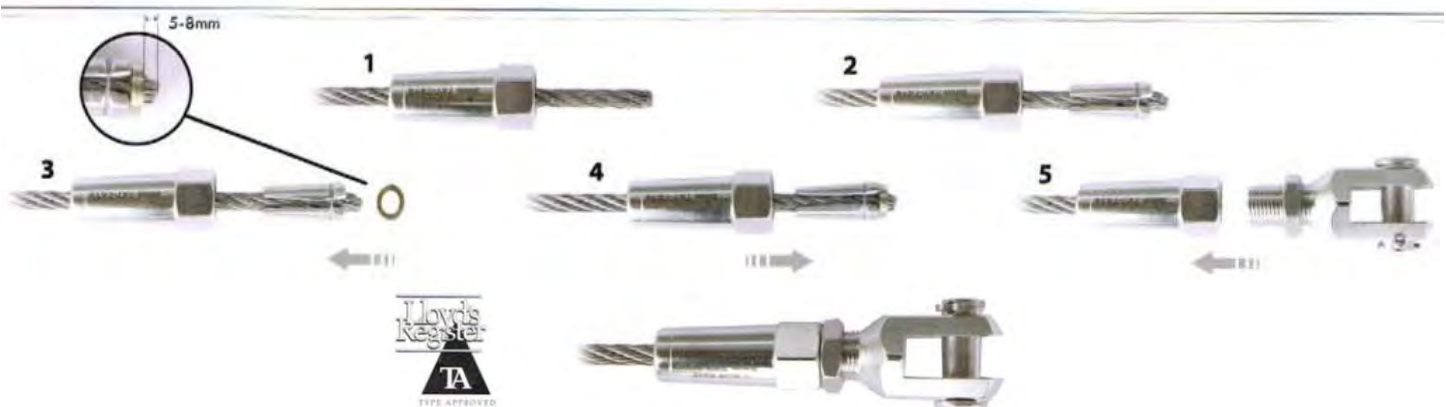

Make sure that the cable matches the terminal.

The SS terminal use only for 8mm 7x7 and 7 x 19 Stainless Wire.

Do no reuse jaws or house.

- 1 Slide the jaw housing in place on the cable.
- 2 Slide the jaws onto the cable, ensuring there is equal space between the jaws.
- 3 Place the brass pressure ring on the end of the cable. Make sure that the distance from the pressure ring to the end of the cable is 5-8mm.
- 4 Slide the jaw housing over the jaws.
- 5 The terminal can now be assembled. Screw the head on the jaw housing with a torque wrench – **min. 58 Nm (43Lbf ft)**, Tighten the lock nut with **min. 50 Nm (36 Lbf ft)**.

Note: after the first dynamic load the terminal **MUST** be tightened again. When assembling Swageless Terminals the breaking strength of the cable will be reduced by 0-15%.

The user is responsible for choosing the proper cable, and for correct assembly.



APPENDIX A – CRIMPED FITTINGS

INSTALLATION

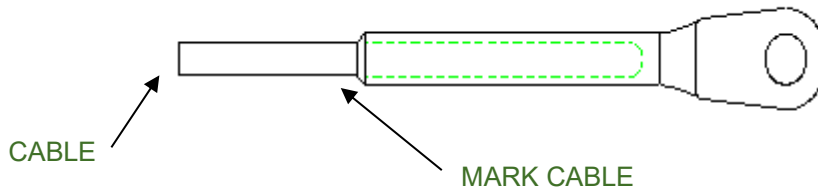

1. Insert the cable into the open end of the fitting to be swaged, mark the cable where the cable and the fitting meet. Remove the cable and check that the mark is at least 84mm from the cable end.

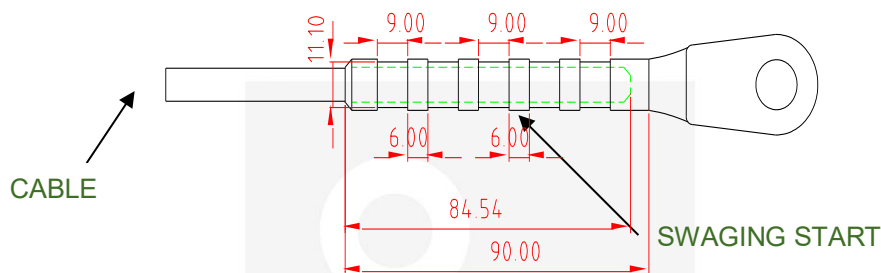

2. Re-insert the cable into the fitting to distance previously marked. Start swaging the fitting from the closed end as shown above. Continue to swage as indicated above 5 times, first swage is 6mm from the depth indicator.
3. Ensure that you can no longer see the mark that was made in Step 1. Check the crimped sections are within the allowable tolerances using Vernier Callipers. (Allowable tolerances = $11.10 \pm 0.2\text{mm}$).

IMPORTANT NOTES TO REMEMBER

- ⚠ Ensure marked cable as indicated in step one is a minimum of 84mm.
- ⚠ Ensure all crimped sections (flat) are with 11.10mm, with a tolerance level of + or - 0.2mm. This distance should be the case of all 8mm 7 x 19 and 7 x 7 cable. The measurement should be taken with Vernier Callipers to ensure accuracy. If your measurements are outside the acceptable tolerance range this can be a sign of either a loss of pressure in your swaging tool or an indication that your dies are worn or incompatible. Any swaging that occurs outside the acceptable tolerances will need to be restarted using the appropriately amended tools.
- ⚠ When swaging the cable the mark made in step 1 will disappear during the final swage due to the lengthening of the material during the swaging operation.
- ⚠ The swaged end has a mark indicating the end of the solid section of the unit and the start of the hollow section. Start swaging 6mm from the mark indicating the solid section.
- ⚠ When completed the swaged section should be a minimum of 80mm long. The dies are made with a 9mm wide section to crimp. These 9mm crimping sections need to be completed 5 times, that is there will be five flat sections along the swaged end. In between each crimped section you need to maintain a distance of between 5 and 6mm.
- ⚠ **DO NOT** swage the solid section indicated by the mark on the unit this will damage the swaging tool and the dies. (Marking the swaging depth on the end to be swaged unit (84mm from the opening will help to avoid this). To do this, use Vernier Callipers, checking the maximum size and minimum size.

⚠ A FALL RESCUE PLAN SHOULD BE DEVELOPED PRIOR TO USING SAFETYLINK EQUIPMENT.

CONNECTING TO THE LIFE LINE SYSTEM

1. Remove the Karabiner from the FrogLine Shuttle. The supplied Karabiner is a SafetyLink steel trilock and needs three distinct movements to be removed from the shuttle (Slide gate up, twist gate, depress gate).
2. Slide the inner component of the FrogLine shuttle to the right or left of the shuttle body. This will put the two shuttle karabiner connecting holes adjacent to each other and widen the mouth of the shuttle. The shuttle is now in the open position and can be placed face down onto the lifeline cable.
3. To lock the shuttle onto the cable, push the inner component from its position to the right or left back across the shuttle body. This will re-align the karabiner connection holes and narrow the mouth of the shuttle. Insert the SafetyLink Karabiner through both connecting holes. This locks the shuttle body and inner component of the shuttle together and ensures the shuttle remains in the closed position. Check that the Karabiner has locked correctly. The Shuttle is now secured to the life line system.
4. It is a requirement when connecting a lanyard between the users harness and FrogLine shuttle/lifeline system that a personal tear web energy absorber be used. This tear web energy absorber needs to be at the harness end of the lanyard to ensure maximum energy absorption.

⚠ Make sure you are safe at all times whilst attaching or detaching from the FrogLine system.

PROGRESSING ALONG THE LIFE LINE SYSTEM

1. Always progress the system manually. Do not progress in any vehicle or motioning device.
2. When progressing towards a corner, to ensure the FrogLine Shuttle continues on a smooth path avoid cutting the corner sharply.
3. Do not place any tools or equipment onto the life line system.

DISCONNECTING FROM THE LIFE LINE SYSTEM

1. If you are attaching to an alternative fall arrest system ensure you are attached to that system before disconnecting from the FrogLine System.
2. Unlock Karabiner and detach it from the FrogLine Shuttle.
3. Slide the inner component of the FrogLine shuttle to the right or left of the shuttle body. This will put the two shuttle karabiner connecting holes adjacent to each other and widen the mouth of the shuttle. The shuttle is now in the open position and can be removed from the lifeline cable.
4. Slide inner component of the Shuttle into original position and insert Karabiner through the two connecting holes to store.



⚠ REMEMBER YOU MUST BE SAFE AT ALL TIMES.

Where a risk of a fall exists on entering or exiting the life line system additional fall prevention measures must exist. Where additional fall prevention exists on entry and exit the user must ensure:

1. They are attached to the life line system before detaching from the additional fall prevention measure.
2. DO NOT detach from the life line system unless they are attached to the additional fall prevention measure.

EXAMPLE: LAYOUT OF LIFELINE SYSTEM

SETTING OUT: STEEL PURLINS BELOW 25 DEGREES

⚠ SURFACE MOUNTED ANCHORS SHOULD BE POSITIONED 2 METRES FROM THE EDGE ON KLIPLOK ROOFS.

All working at heights safety procedures must be complied with when installing SafetyLink height safety systems. For more information refer to your state or territories current legislation, regulations, policies and codes of practices. Horizontal height safety lifelines must only be installed and used by competent people with relevant current height safety qualifications.

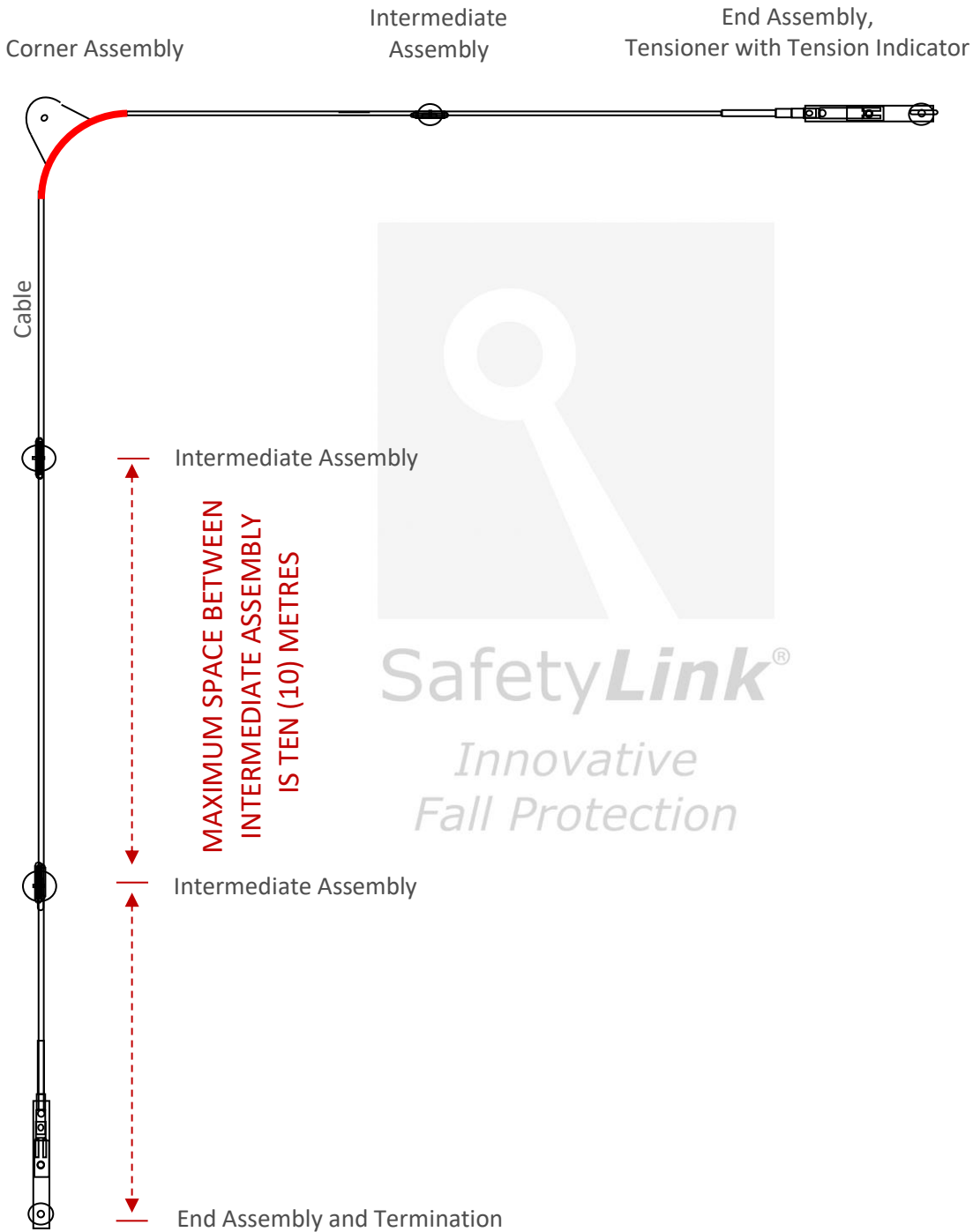

This is a guide only

SAFETYLINK HEIGHT SAFETY SYSTEMS MUST ONLY BE INSTALLED AS PER OUR INSTALLATION GUIDES, TO STRUCTURES AS SPECIFIED IN THE INSTALLATION MANUAL FOR EACH PRODUCT. SHOULD ANY DOUBT EXIST IN REGARDS TO THE STRUCTURES INTEGRITY AN ENGINEER SHOULD BE CONSULTED.

IN CASE OF ACCIDENT

- ⚠️ A FALL RESCUE PLAN SHOULD BE DEVELOPED PRIOR TO USING SAFETYLINK EQUIPMENT.**
- ⚠️ PERSONS WORKING AT HEIGHTS SHOULD NOT WORK ALONE.**

It is critical that before using any SafetyLink Systems a fall rescue plan is in place for any persons suspended mid-air following a fall. Serious injury or death can occur in a matter of minutes, particularly if a person's movement or breathing is restricted or loss of consciousness has occurred. In accordance with your fall rescue plan and appropriate first aid procedures it is essential to remove the person from the suspended position as quickly as possible.

IN ACCORDANCE WITH AS/NZS 1891.4:2009 CLAUSE 9.5

EQUIPMENT WHICH HAS ARRESTED A FALL OR SHOWS A DEFECT

Any piece of equipment including both personal and permanently installed items, which has been used to arrest a fall or which shows any defect during operator or periodic inspection shall be withdrawn from service immediately and a replacement obtained if necessary. A label indicating the condition or defect should be attached to the equipment, and it should be examined by a competent person who will decide whether the equipment is to be destroyed or repaired if necessary and returned to service. In the latter case, details of any repair shall be documented and a copy given to the operator.



Terms/Conditions/Warranties

DISTRIBUTOR:

SafetyLink Pty Ltd | ABN 83 081 777 371
Phone: 1300 789 545 or +61 2 4964 1068 | Fax: 1300 738 071 or +61 2 49641069
info@safetylink.com | www.safetylink.com