

# Miller SkyORB™ Overhead Rotational Boom Anchor

## Description

The Miller SkyORB Anchor is a specially-engineered overhead rotational boom anchorage system, which provides a safe, mobile, easily accessible and viable fall arrest anchorage point for workers in applications, such as vehicle loading /unloading and maintenance, where overhead structures are not available for tie-off.

## Materials

<b>General Construction:</b>	Welded Steel
<b>Steel Components:</b>	1026 Alloy; A36 Alloy; Zinc Primer and Powder Coat
<b>Load Bearing Hardware:</b>	Zinc-Plated Steel (grade 8); Stainless Steel (18-8, 303, 304)
<b>Other Components:</b>	Polyethylene Caps; Nylon 6/6 Spacers; Teflon PTFE Tape
<b>Cable Assembly:</b>	316 Stainless Steel; Zinc-Plated Steel; Stainless Steel 1x19 8mm Cable

## Technical

<b>Max. Capacity:</b>	310 lbs. (140.6kg)
<b>Design Factor:</b>	2:1 for 900 lb. (4kN) maximum fall arrest force and maximum work radius of 14 ft. (4.3m)
<b>Max. Work Radius:</b>	14 ft. (4.3m) maximum work radius, 360° (when used with a truck as counterweight) - see Fig. 4b; 14 ft. (4.3m) maximum work radius, 180° opposite from counterweights (when used with alternate counterweights) - see Fig. 4d
<b>Proof Load:</b>	1,800 lbs. (8kN) in direction of fall; 36,000 ft.-lbs. (48,000 Nm) at center of base

## Possible Connection Heights (from Ground Level to SRL Anchor Point)

240 in. (20') - (6.1m) - Pin in top position
228 in. (19') - (5.8m)
216 in. (18') - (5.5m)
204 in. (17') - (5.2m)
192 in. (16') - (4.9m)
180 in. (15') - (4.6m) - Lowest pin position
168 in. (14') - (4.3m) - Pin removed ( <i>unit may be harder to turn without pin</i> )

**ALWAYS** calculate fall clearance required based on the connection height (from work platform to SRL anchor point) being used.

Connection Heights are approximate and may be slightly different in reality due to cable and shock absorber length differences. Please allow at least 6 in. (152.4mm) above these values for overhead clearance. Always check for clearance before moving through passageways to avoid damage to the unit or possible tipping. The boom can be lowered (by disconnecting the cable) to provide overhead clearance of 40 in. (1.02m) less than above values (making the unit height 46 in. (1.12m) less than normal height).

## Compliance

Meets OSHA 1926.502 Subpart M

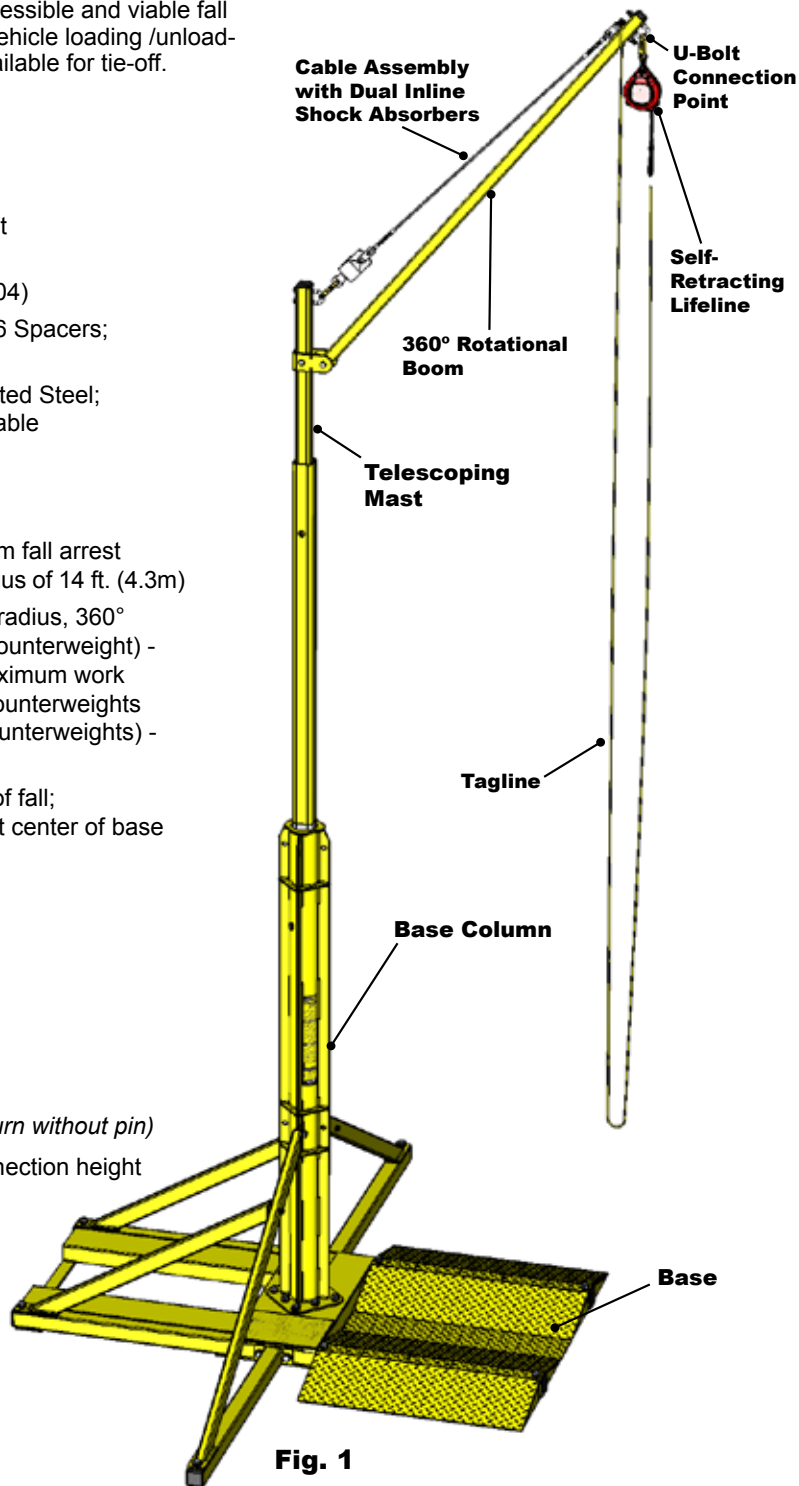

**Fig. 1**

*\*Lifting straps included with SkyORB System;  
SRL not included.*

# Miller SkyORB™ Overhead Rotational Boom Anchor

SKU/Description	Weight	Height	Width	Depth
<b>SORBSYS</b> SkyORB Anchorage System	1050 lbs. (476.3kg)	240 in. (6.1m)	133 in. (3.38m)	97 in. (2.46m)
SkyORB Anchorage System, packaged	1530 lbs. (693kg)	20-3/4 in. (0.53m)	40-1/2 in. (1.03m)	122 in. (3.10m)
<b>SORBCABLEKIT</b> Repair Kit - Includes cable with swaged ends, two (2) shock absorbers, a clevis and pin, and one (1) carabiner	8 lbs. (3.63kg)	72 in. (1.83m)	6 in. (0.15m)	6 in. (0.15m)
<b>1901AL3/3FT</b> 3 ft. (0.9m) Lifting Strap	1 lb. (0.45kg)	12 in. (0.3m)	3 in. (0.08m)	3 in. (0.08m)

**Fig. 2a**

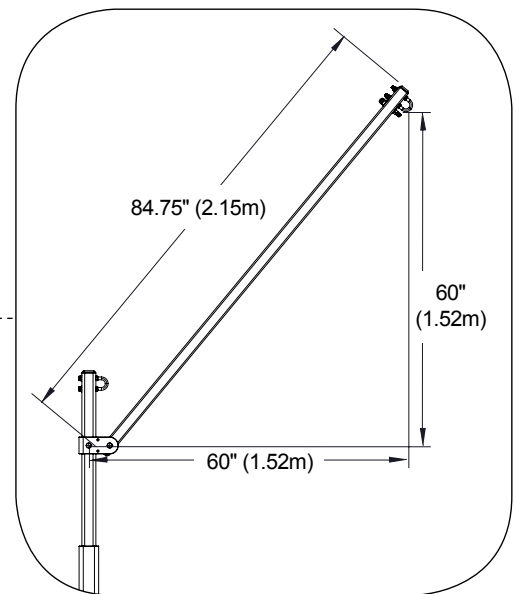
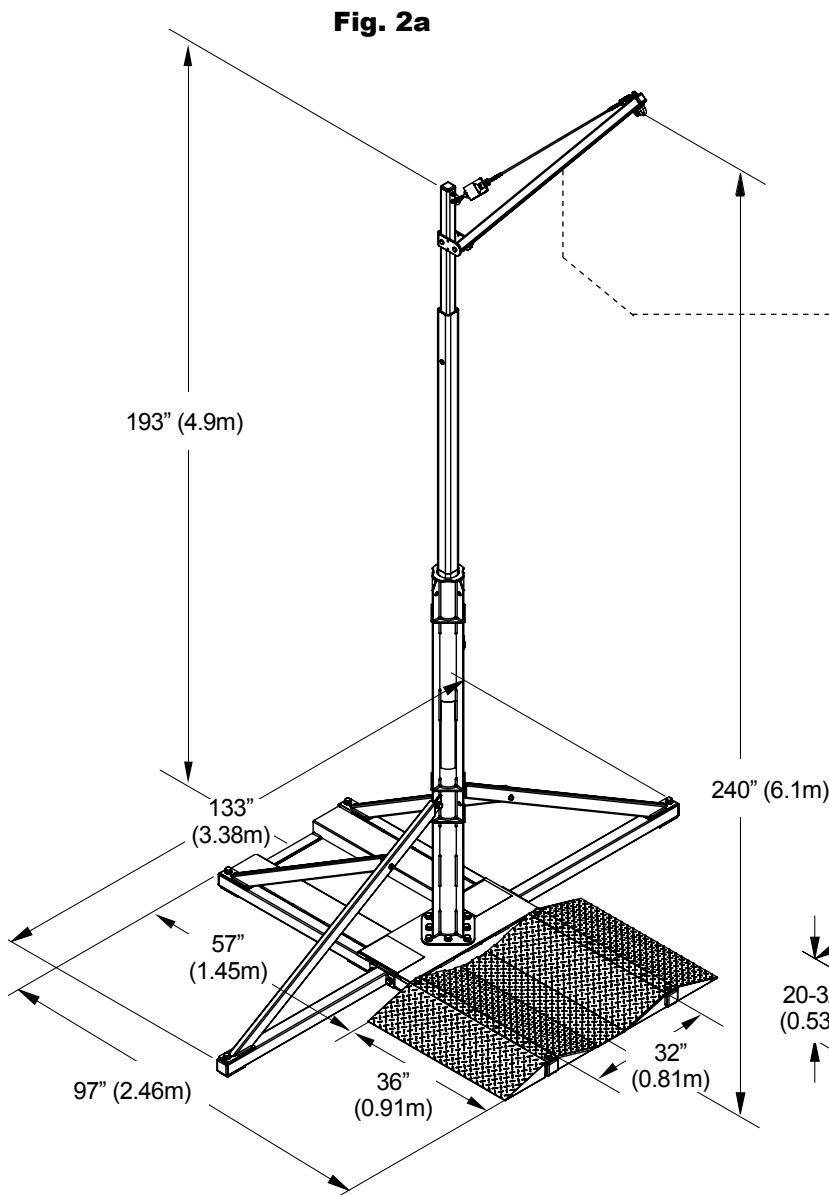

**Fig. 2b**

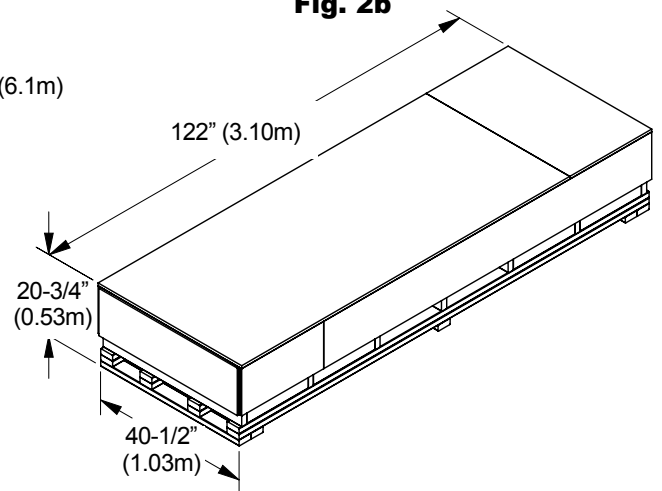

# Miller SkyORB™ Overhead Rotational Boom Anchor

## Application Restrictions

1. This device is intended for use with equipment and accessories manufactured and/or approved by Honeywell Safety Products. Accessories are subject to various application restrictions as outlined in the application accessory specifications sheets.
2. Anchoring to an attendant vehicle may not be permitted within certain jurisdictions. Ensure that the use of this equipment does not violate any regulations within your area.
3. Each installation must be approved to local standards by a qualified engineer.
4. This device must be used with a truck or counterweights in place. When a truck is used as counterweight, it must be impossible to be removed while the system is in use. The wheel placed on the wheel well baseplates must have an axle weight or be part of a tandem axle set with a weight of at least 10,000 lbs. (4535kg). See Truck/Counterweight Requirements for additional information.
5. All connectors, including snap hooks and carabiners, attached to this system must be compliant with OSHA 1926.502M.
6. This system is tested to meet a static strength of at least 1,800 lbs (8kN) in the direction of possible loading. The attached fall arrest connecting device must limit the maximum fall arrest force to 900 lbs (4kN) or less when attached to this system. All self-retracting lifelines (SRLs) marked with a 900 lb (4kN) maximum arrest force when tested to OSHA 1926.502M can be used with this system. Honeywell recommends the use of the Miller Falcon Self-Retracting Lifeline MP20 Series and the Miller MightyLite Self-Retracting Lifeline RL20 Series. When there is a potential for the lifeline to come in contact with sharp edges, Honeywell recommends the use of the Miller MightyLite Leading Edge Self-Retracting Lifeline RL20-LE Series.
7. Fall clearance must be maintained for the attached self-retracting lifeline (SRL). To determine fall clearance for an application, visit [www.millerfallprotection.com/fallclearance](http://www.millerfallprotection.com/fallclearance). For the purposes of calculating fall clearance, the connection height of the SRL is measured from the work platform and the work radius is measured from the SRL's connection point. Therefore, the maximum work radius from the anchor point is 9 feet (2.7m), and the connection height can range from 6 feet to 14 feet (1.8m to 4.3m). Always account for swing fall in terms of both the additional free fall that will be present, and the possibility of striking obstacles due to lateral movement during fall. Swing fall should always be limited if possible.

## Site Requirements

An approximate area of 30 ft. x 20 ft. (9.1m x 6.1m) is required to enable easy set-up of the system. This area should be on flat, level, stable ground to prevent difficulty with forklift operation during installation. The area should be free of debris and obstacles to ensure maximum safety. Any variations in ground flatness may also cause difficulty in fitting mating parts together. See Fig. 3 below for two recommended set-up patterns.

**Fig. 3**

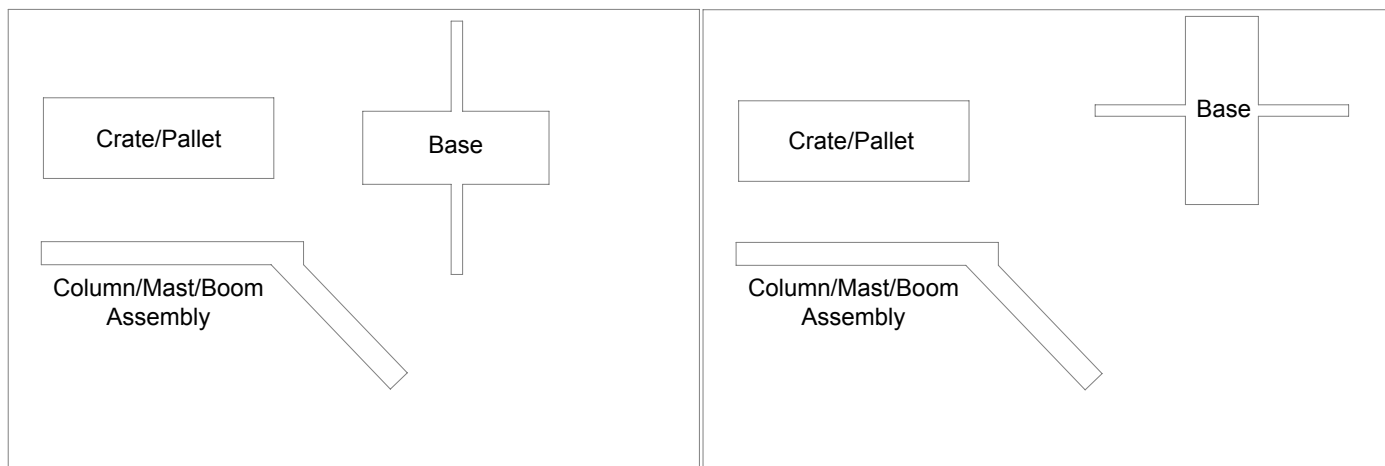

The ground/floor/pavement where the SkyORB anchorage system will be used must also be flat, level, stable and able to withstand the weight of the truck(s). Do not use on loose gravel, soft ground, uneven surfaces, surfaces sloped more than 5 degrees, or on any surface which may become excessively compliant when wet.

Fully set-up SkyORB systems may be moved from one location to another with a forklift. See instructions for additional details.

# Miller SkyORB™ Overhead Rotational Boom Anchor

## Truck / Counterweight Requirements

The SkyORB anchorage system requires a truck's weight to secure it for fall protection use.

- The wheel of the truck (or other vehicle) must have a **minimum axle weight or tandem axle weight of 10,000 lbs. (4,535kg)** of force exerted onto the wheel well baseplates. Axle weight is the weight placed on the road by all wheels of one axle; Tandem axle weight is the total weight placed on the road by two or more consecutive axles whose centers are spaced more than 40 inches (1.016m) apart, but not more than 96 inches (2.438m) apart. The Federal tandem-axle weight limit on the Interstate System is 34,000 lbs. (15,422kg). The baseplate has been tested to readily withstand up to 20,000 lbs. (9,072kg) axle weight on the ramps and wheel well. However, higher loading may be deemed safe by a qualified person as long as no component of the base is visibly damaged or deformed.
- Wheel diameter is recommended to be less than 6 ft. (1.8m) in diameter with an overall width of less than 36 in. (0.91m). For vehicles with wheel dimensions outside these parameters, a qualified person must ensure that the wheel is retained within the wheel well and that the SkyORB is stable and can be safely used with the alternative wheel size.
- Truck ground clearance should be no less than 4-1/2 inches (115mm) to clear the ramps, wheel well, and hardware.

Any vehicle may be used to secure the SkyORB system as long as it meets the above requirements. Special precautions must be taken with non-wheeled vehicles, especially tracked vehicles. More than one SkyORB system may be secured with the same truck as long as the axle/tandem axle and wheel requirements are met by the truck for each SkyORB system.

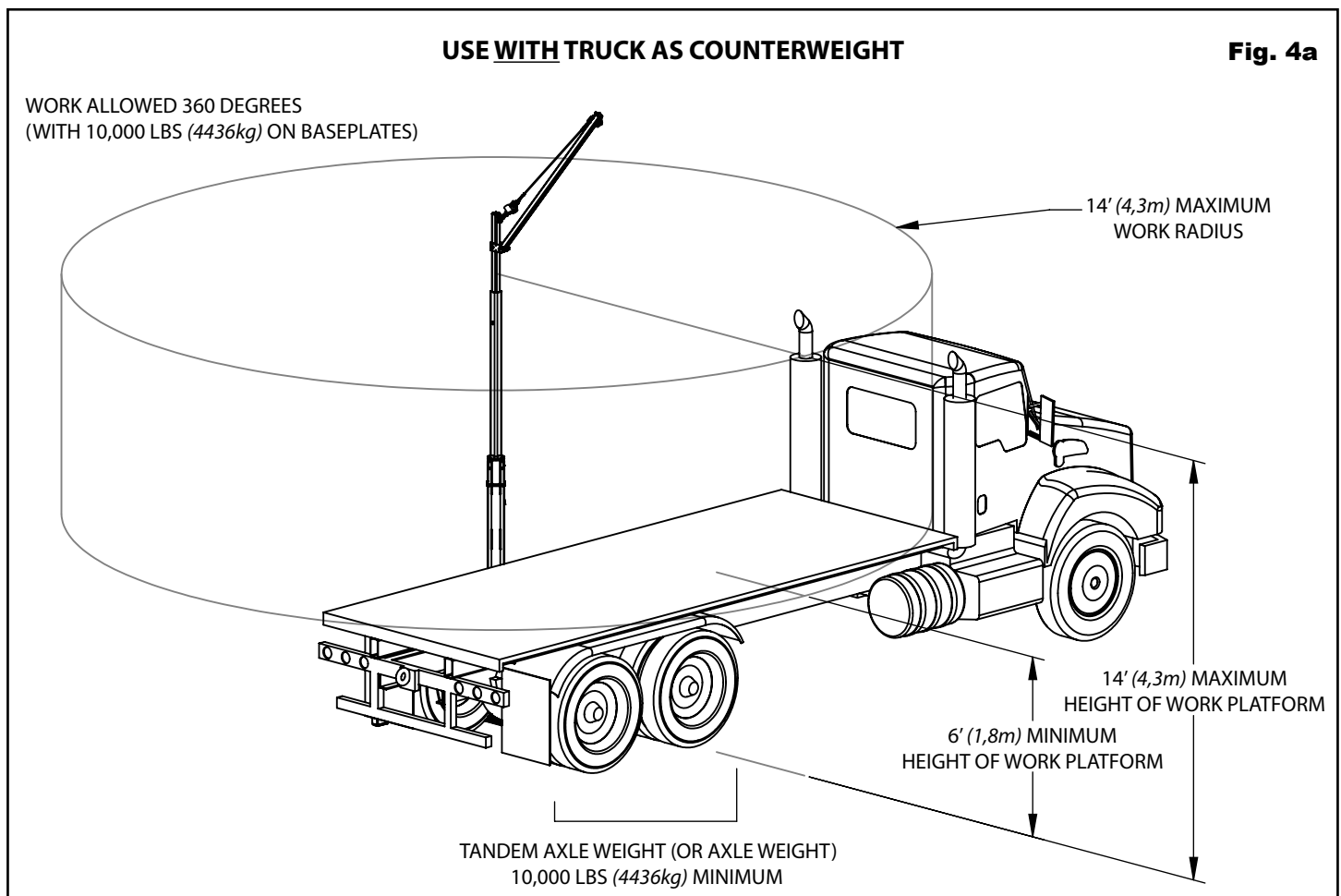

# Miller SkyORB™ Overhead Rotational Boom Anchor

## Truck / Counterweight Requirements cont'd

Counterweights may be used in place of a truck if needed or preferred.

- The counterweights must have a minimum weight of 5,000 lbs. (2268kg).
- The counterweights must be placed on the opposite side of the work area and must be evenly distributed over an area of 30" x 40" (762mm x 1016mm). Counterweights longer than 40" (1016mm), which extend beyond the system base by up to 12" (305mm), must be supported.
- Counterweights must be stable and solidly attached to the base by straps or otherwise.

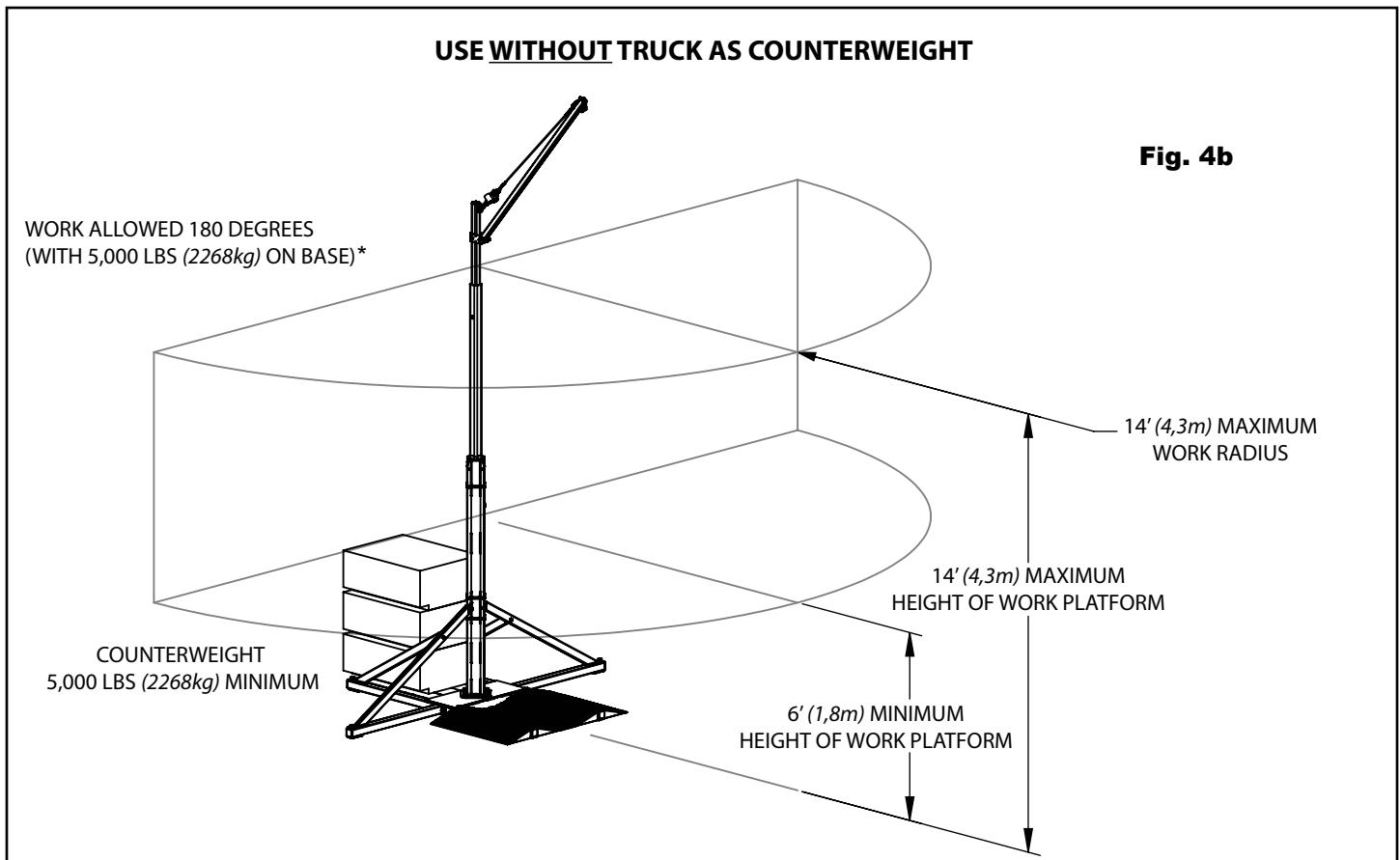

\*Work can be performed at 360 degrees while using counterweights (without a truck), but only in the case that 5,000 lbs. (2268kg) is applied opposite of BOTH work zones. In other words, counterweight of 5,000 lbs. (2268kg) must also be applied in the wheel well area. In this case, the outer ramps and bolts may be excluded, and the counterweights must all be rigidly attached to the system.

# Miller SkyORB™ Overhead Rotational Boom Anchor

## Personnel, Equipment and Tool Requirements

Set-up requires one forklift operator and one additional worker to perform steps in tandem with the forklift operator. The following equipment and tools are required:

- To open crate
  - #2 Square Driver
- To set up system
  - Forklift with 16 ft. (4.88m) vertical reach (see additional forklift requirements below)
    - 1-1/8" (28.575mm) wrench
    - 1-1/8" (28.575mm) ratcheting socket wrench or impact wrench
    - 3/4" (19mm) wrench

### Forklift Requirements

Fig. 5a

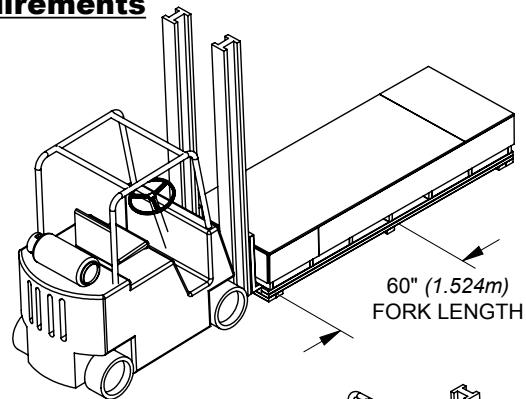
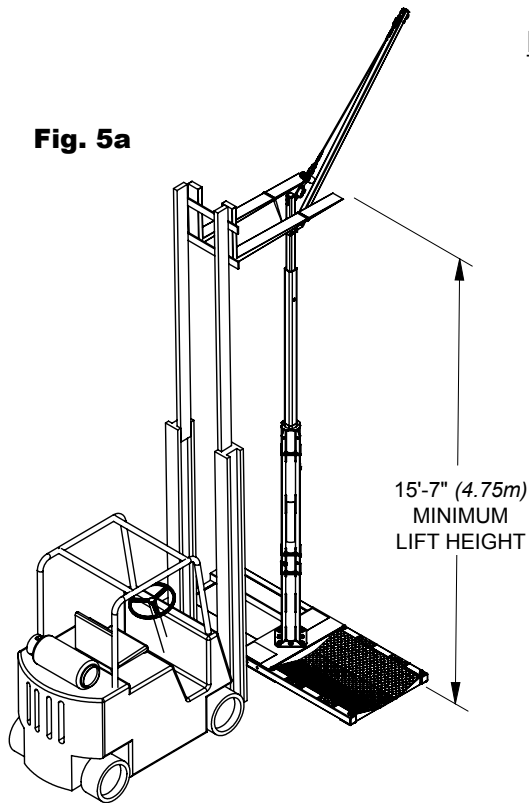

Fig. 5b

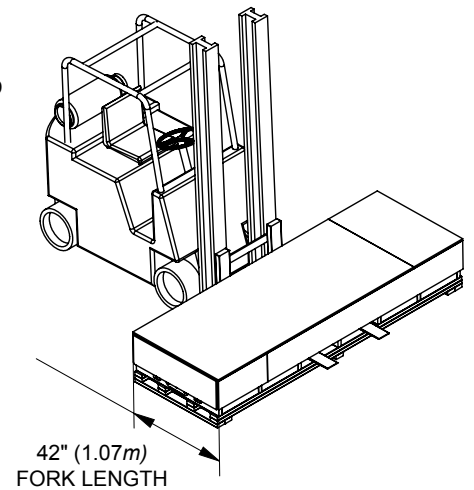
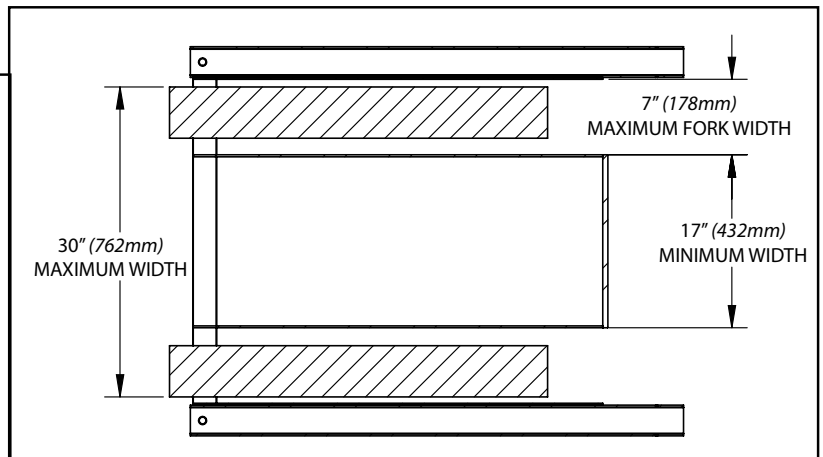
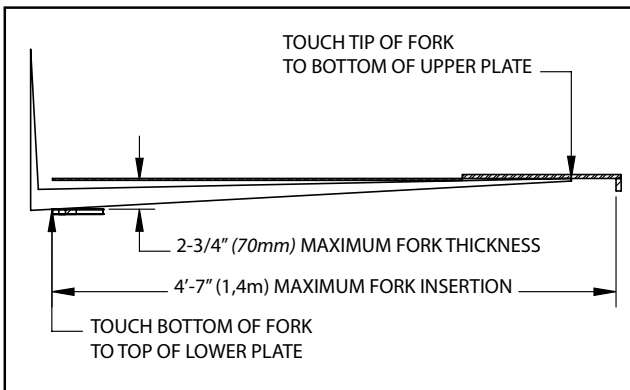

Fig. 5c - Fork Requirements for Compatibility with SkyORB Base Forklift Pockets



# Miller SkyORB™ Overhead Rotational Boom Anchor

## Hardware Specifications

Fig. 6a

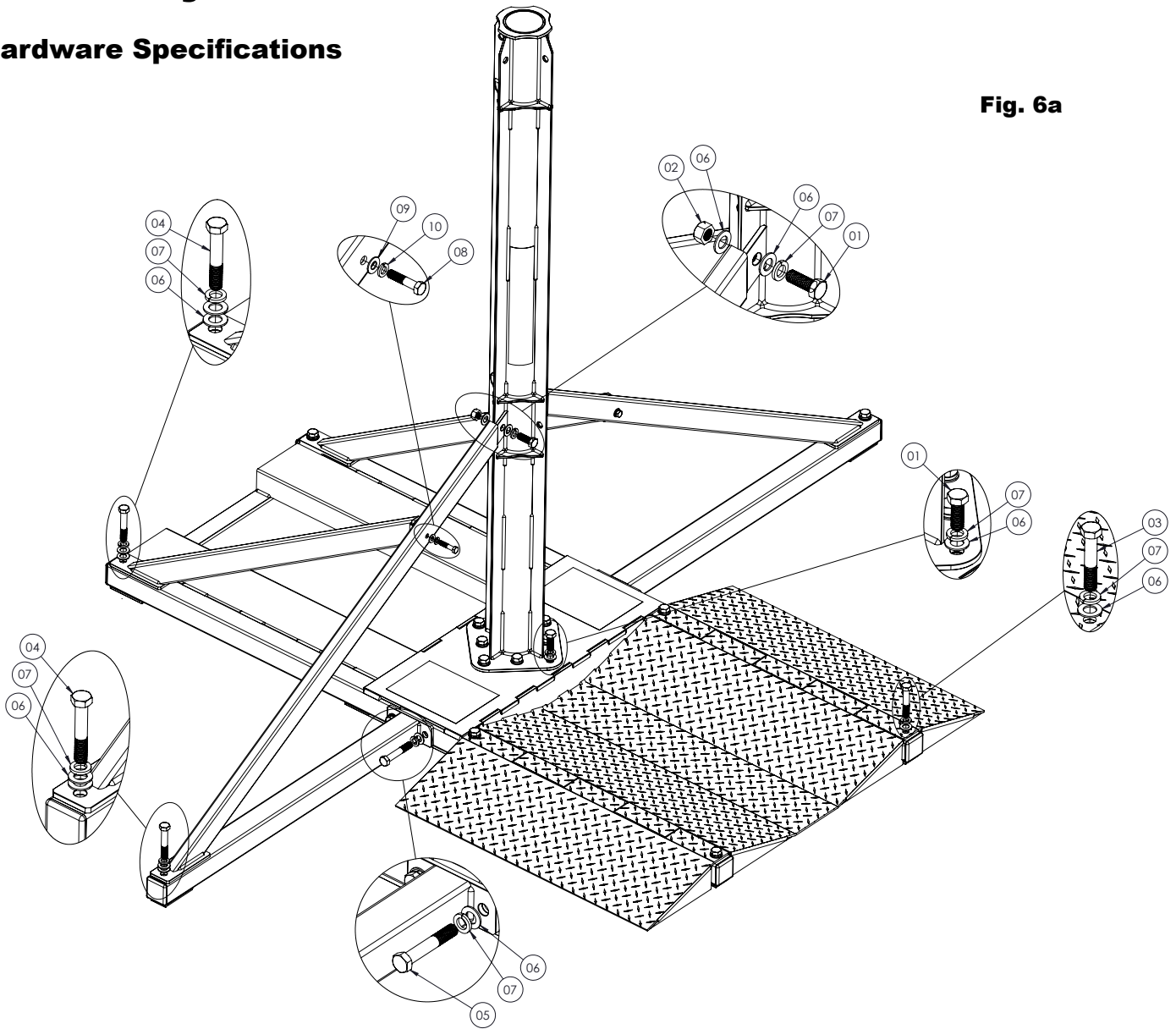

### Base Assembly

Reference No.	Hardware Component and Description
01	3/4-10 x 2" LG. HEX HEAD SCREW - GRADE 8 ZINC PLATED ALLOY STEEL
02	3/4-10 HEX NUT - GRADE 8 ZINC YELLOW-CHROMATE PLATED STEEL
03	3/4-10 X 4" LG. HEX HEAD SCREW - GRADE 8 ZINC PLATED ALLOY STEEL
04	3/4-10 X 4 1/4" LG. HEX HEAD SCREW - GRADE 8 ZINC PLATED ALLOY STEEL
05	3/4-10 X 4 1/2" LG. HEX HEAD SCREW - GRADE 8 ZINC PLATED ALLOY STEEL
06	3/4" STANDARD FLAT WASHER - ZINC PLATED STEEL
07	3/4" SPLIT LOCK WASHER - ZINC PLATED STEEL
08	1/2-13 X 2 1/4" LG. HEX HEAD SCREW - GRADE 8 ZINC PLATED ALLOY STEEL
09	1/2" STANDARD FLAT WASHER - ZINC PLATED STEEL
10	1/2" SPLIT LOCK WASHER - ZINC PLATED STEEL

# Miller SkyORB™ Overhead Rotational Boom Anchor

**Fig. 6b**

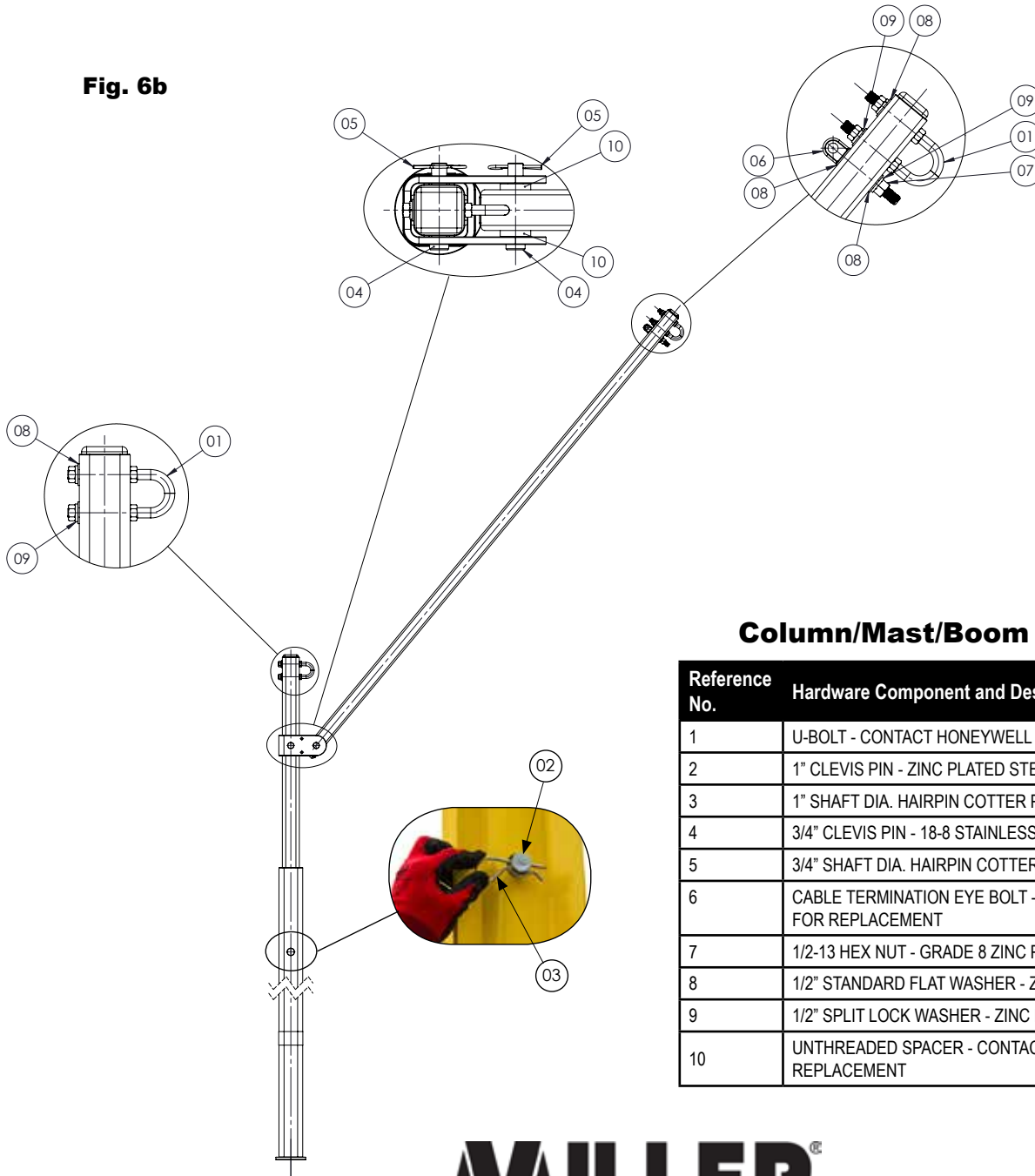

## Column/Mast/Boom Assembly

Reference No.	Hardware Component and Description
1	U-BOLT - CONTACT HONEYWELL FOR REPLACEMENT
2	1" CLEVIS PIN - ZINC PLATED STEEL
3	1" SHAFT DIA. HAIRPIN COTTER PIN - ZINC PLATED STEEL
4	3/4" CLEVIS PIN - 18-8 STAINLESS STEEL
5	3/4" SHAFT DIA. HAIRPIN COTTER PIN - ZINC PLATED STEEL
6	CABLE TERMINATION EYE BOLT - CONTACT HONEYWELL FOR REPLACEMENT
7	1/2-13 HEX NUT - GRADE 8 ZINC PLATED STEEL
8	1/2" STANDARD FLAT WASHER - ZINC PLATED STEEL
9	1/2" SPLIT LOCK WASHER - ZINC PLATED STEEL
10	UNTHREADED SPACER - CONTACT HONEYWELL FOR REPLACEMENT



by Honeywell

Toll Free 800.873.5242 (press 4) • [hsptechsupport@honeywell.com](mailto:hsptechsupport@honeywell.com) • [www.millerfallprotection.com](http://www.millerfallprotection.com)

**▲ WARNING!** THIS DOCUMENT PROVIDES AN OVERVIEW OF FALL PROTECTION PRODUCTS AVAILABLE FROM HONEYWELL AND CARE HAS BEEN TAKEN TO ASSURE THE ACCURACY OF THE DATA. IT DOES NOT PROVIDE IMPORTANT PRODUCT WARNINGS AND INSTRUCTIONS. HONEYWELL RECOMMENDS ALL USERS OF FALL PROTECTION EQUIPMENT UNDERGO THOROUGH TRAINING, AND THAT ALL WARNINGS AND INSTRUCTIONS PROVIDED WITH THE PRODUCTS BE THOROUGHLY READ AND UNDERSTOOD PRIOR TO EACH USE. FAILURE TO READ AND FOLLOW ALL PRODUCT WARNINGS AND INSTRUCTIONS COULD RESULT IN SERIOUS INJURY OR DEATH.