



Product Specifications

Model: PH Series Personnel Hoist (Small Chassis)

The Pelsue PH Series Personnel Hoist is designed as a personnel hoisting and/or rescue & retrieval device. This specification sheet applies to all Pelsue PH Series Hoists constructed on the “small” chassis. Below is a table of the Pelsue Hoist Models incorporating the “small” chassis and information on the cable/rope size included. The standard end fitting included on all rope or cable assemblies is an ANSI Z359 compliant swiveling snap hook. This is the preferred method of connecting to a harness or carabiner, but alternate end fittings are available upon request. Hoists built on medium and large chassis’ are also available in order to accommodate longer lengths of rope or cable. The PH Series Personnel Hoist is equipped with a standard Pelsue Quick-Release bracket, other adapter brackets can be supplied or added upon request.

Load Capacity:

Pelsue PH Series Hoists are designed and tested as Mechanical Retrieval Devices as defined in OSHA 1910.146 & ANSI Z117.1. PH Series Hoists are approved for use with personnel and are intended to facilitate hoisting and/or rescue & retrieval operations when required.

Load Capacity..... 310 LBS. (140 KG)

Gear Ratio..... 5 to 1

Rope & Cable Assemblies:

3/16” Stainless Steel Wire Rope:

Minimum Breaking

Strength..... 3500 LBS. (1587 KG)

1/4” Synthetic Rope:

Minimum Breaking

Strength.....5500 LBS. (2494 KG)

Weight:

PH07R (Synthetic Rope).....21 LBS. (9.5 KG)

PH07C (Stainless Steel Cable).....25 LBS. (11.3 KG)

Braking Capabilities:

Primary Double-Function Braking System: PH Series Hoists are equipped with a long-life friction-brake system that is supplemented by a positive-locking double-pawl arrangement.

Secondary Braking System: PH Series Hoists are also equipped with a centrifugal “overspeed” brake for redundancy. This feature completely eliminates the possibility of “free-wheeling” in the event that the primary braking system is disabled.



T.A. Pelsue Company
 2500 S. Tejon St.
 Englewood, CO 80110
 Ph: 1-800-525-8460, (303) 936-7432
 Fax: (303)934-5581
 Web: www.pelsue.com E-mail: sales@pelsue.com

Model #	Length & Type of Hoist Line
PH07R	70' of 3/16" "Technora®" Synthetic Rope
PH07C	70' of 3/16" Stainless Steel Cable

****NOTE -** The PH Series use is only intended for use by a “Competent Person”. Read the Product Manual prior to usage. Ensure that all hoisting and rescue equipment conforms to regulations in affect in your area.



Product Specifications

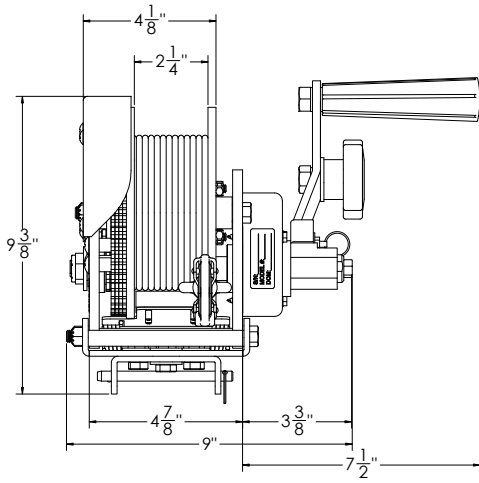

FRONT VIEW

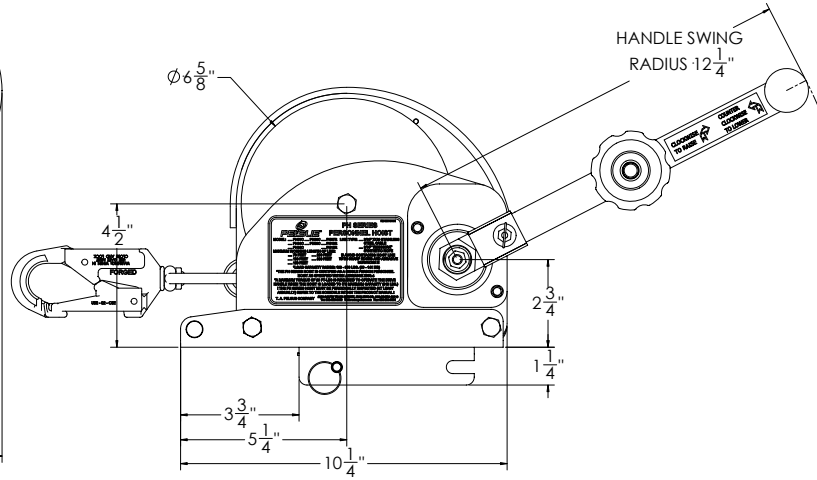

SIDE VIEW

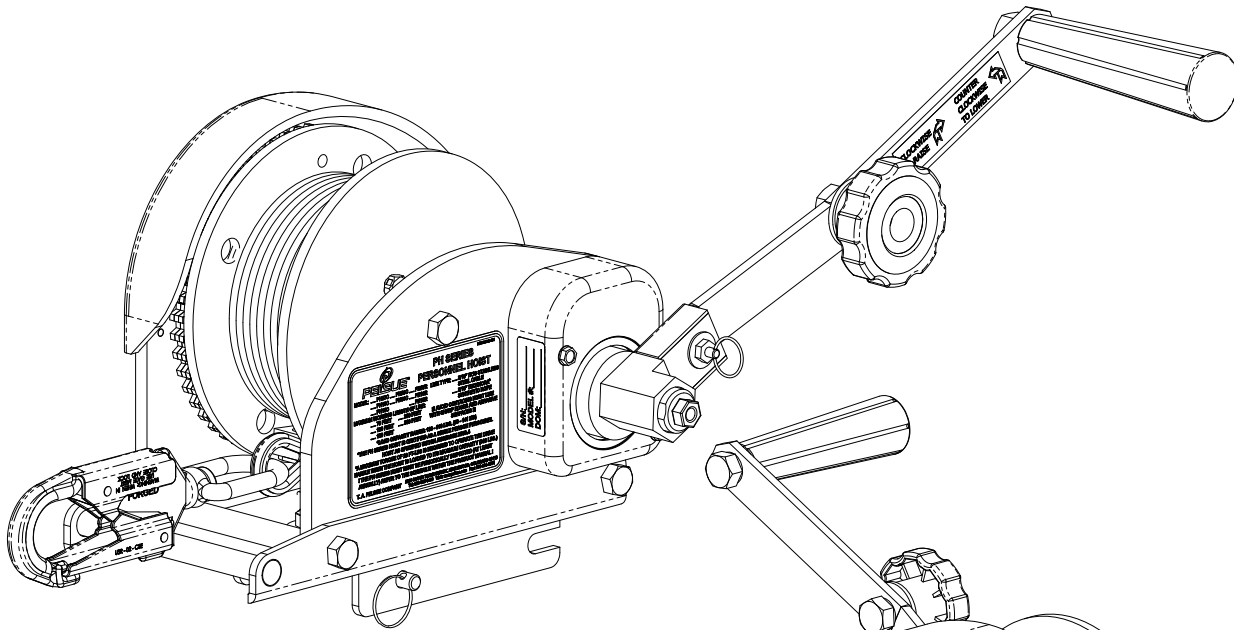

RIGHT ISOMETRIC VIEW

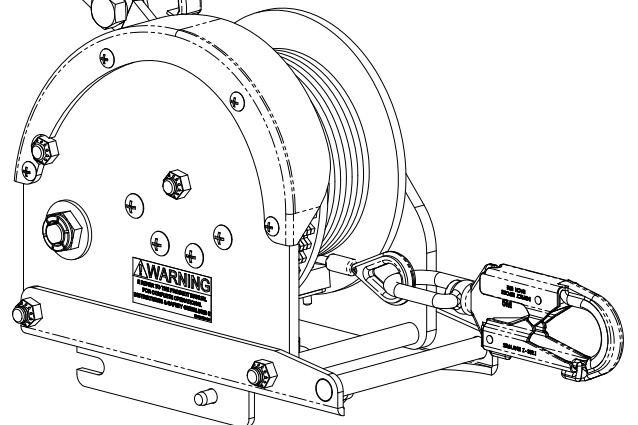

LEFT ISOMETRIC VIEW



T.A. Pelsue Company
 2500 S. Tejon St.
 Englewood, CO 80110
 Ph: 1-800-525-8460, (303) 936-7432
 Fax: (303)934-5581
 Web: www.pelsue.com E-mail: sales@pelsue.com