



Product Specifications

Model: #VHS-A1 Davit Sleeve System, Receiver Hitch-Mounted, Aluminum Stabilizers

The #VHS-A1 Vehicle Hitch Mount Sleeve Davit System provides a secure & compliant receiver socket for a Pelsue #DK series davit kit system. The #VHS-A1 sleeve system is designed to secure in place within a properly-rated 2" square receiver hitch that is securely installed to a vehicle of sufficient gross weight. Also included in the system are a vertical and horizontal stabilizer bar that together provide additional stability as well as the capability to level the #VHS-A1 Sleeve System with the working surface.

General Specifications:

Product is designed and tested as a receiver sleeve system for a Pelsue #DK Series Davit:

Man Rated Load Capacity.....350 LBS. (159 KG.) Maximum User Weight. (Refer to proof load table on reverse side of this document)

Fall Arrest Compliance.....When used in conjunction with a #DK Davit System, the entire system is compliant as an Anchorage as per OSHA 1926 & ANSI A10.14 for one person of 350 LBS. (159 KG.) maximum weight inclusive of all tools and equipment. **!Warning!** A 900 LB. maximum arrest force(MAF) fall arrest device must be used when system is employed as part of a complete fall arrest system.

Materials & Construction:

General Construction

VHS-A1:

- Sleeve Assembly.....Structural Steel
- Stabilizer LegsStructural Aluminum
- Friction LinersABS or PVC
- HardwarePlated Steel

Weight:

- Sleeve Assembly.....33 LBS. (15 Kg)
- Horizontal Stabilizer
Aluminum.....9 LBS. (4.1 Kg.)
- Vertical Stabilizer
Aluminum.....6 LBS. (2.7 Kg.)

Other requirements:

- The #VHS-A1 Davit Sleeve System must be installed properly within a vehicle hitch or other suitable receiver that in itself is installed to a structure or vehicle of sufficient mass to sustain all reported proof loads in order for the complete installed system to conform to the ratings & compliance statement given above.
- The #VHS-A1 Sleeve System is only approved for usage with a DK Series Davit having a maximum offset of 24" *Model #DK1824).

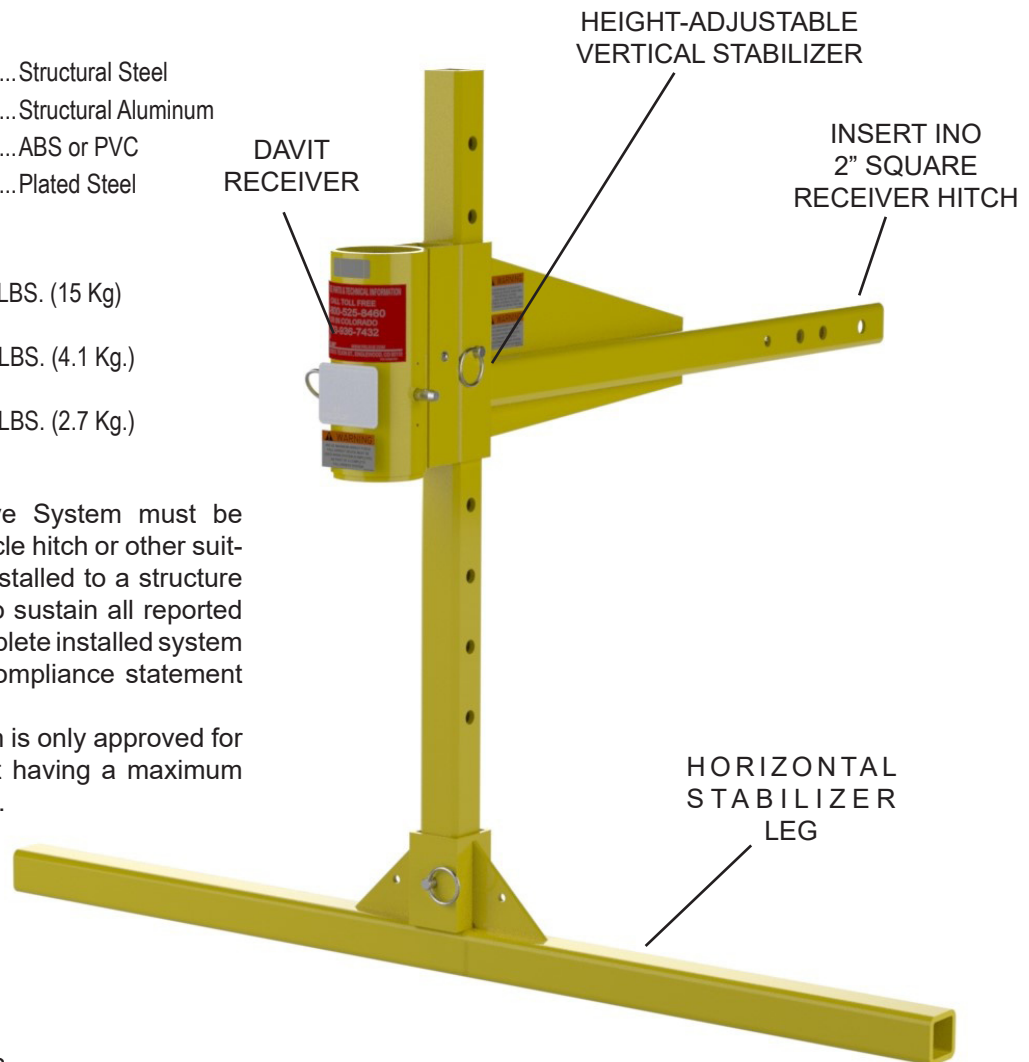

2500 S. Tejon St.
Englewood, CO 80110
Ph: 1-800-525-8460, (303) 936
Fax: (303)934-5581
Web: www.pelsue.com E-mail: sales@pelsue.com



Product Specifications

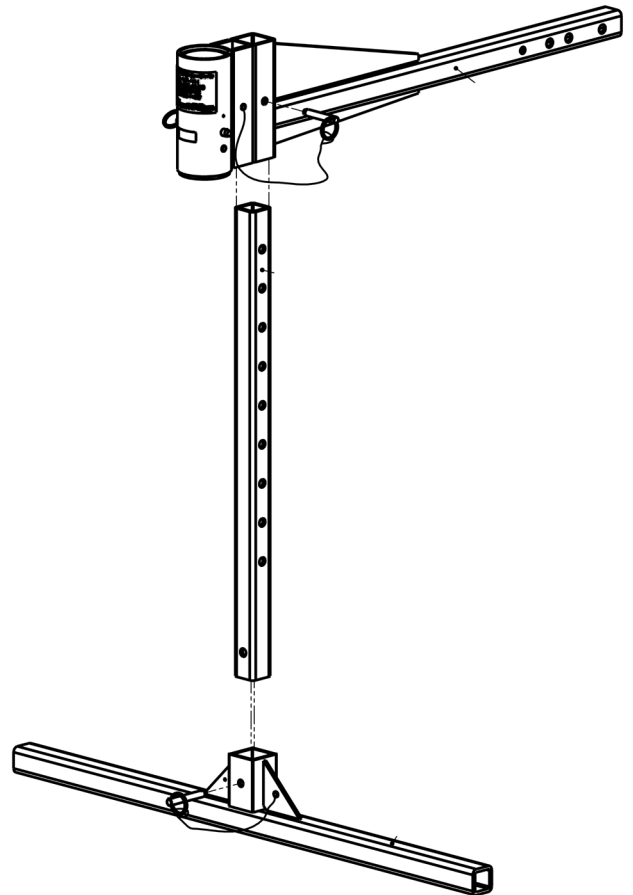
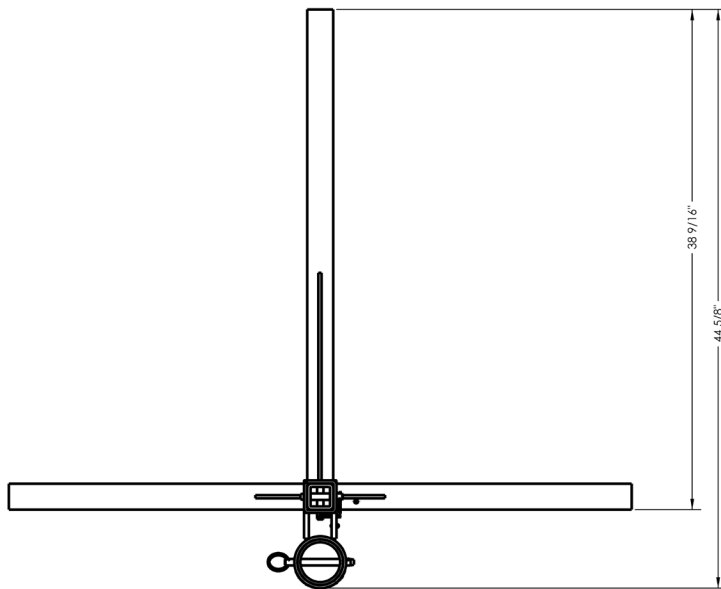
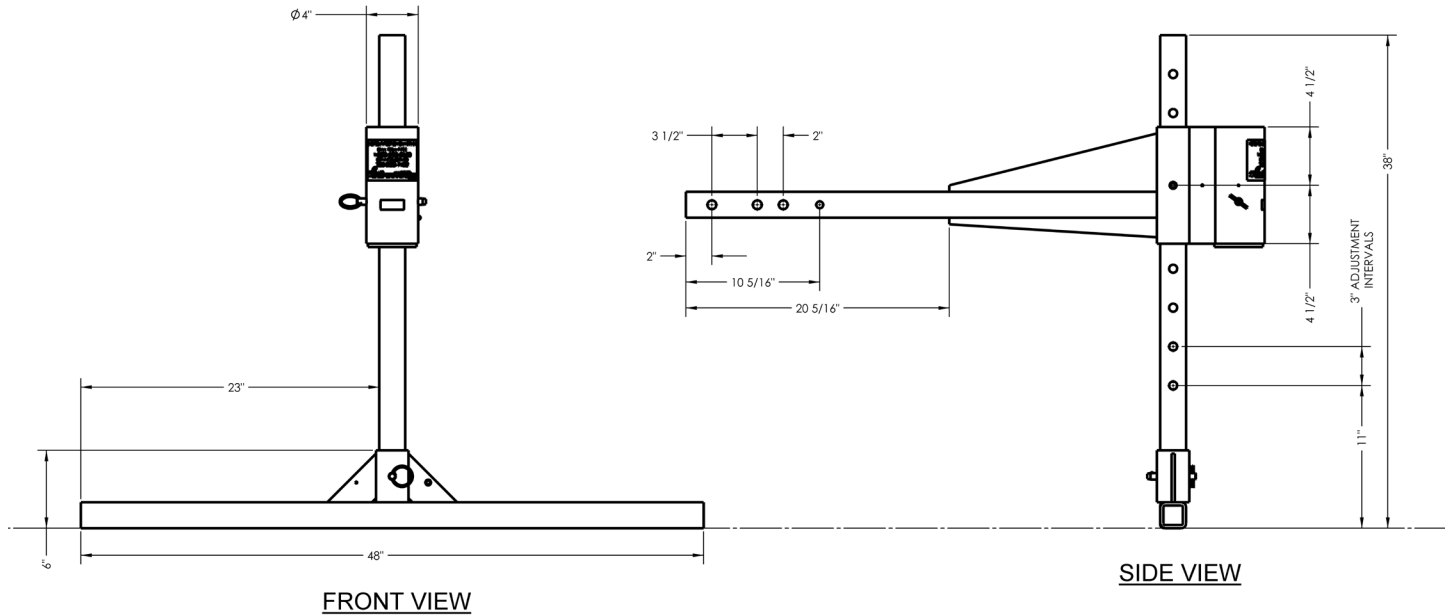

EXPLODED VIEW



2500 S. Tejon St.
 Englewood, CO 80110
 Ph: 1-800-525-8460, (303) 936-7432
 Fax: (303)934-5581
 Web: www.pelsue.com E-mail: sales@pelsue.com